

Invitation to Tender

**MISHRA DHATU NIGAM LIMITED**

(A Govt. of India Enterprise)

P.O. Kanchanbagh, Hyderabad – 500058, India

Phone: 040-2434001 (10 lines), 24184334/24184449, Fax: 040-24340764

Email ID: [karavind@midhani-india.in](mailto:karavind@midhani-india.in), [rakesh@midhani-india.in](mailto:rakesh@midhani-india.in)

Website: [www.midhani-india.in](http://www.midhani-india.in)

**Item Description:** PROCUREMENT OF TUNDISH REFRACTORY  
**Tender Reference** MDN/PUR/TR/MUI/05/19-20

CRITICAL DATES:

**OFFER ACCEPTED TILL : 4<sup>th</sup> DEC 2020**

List of Tender documents:

We have pleasure in enclosing the following documents for the above stores and would invite you to submit your best offer. The following documents shall constitute the tender.

Sl. No	Contents	Annexure
1.	Technical Specification and Scope of work	Annex – I
2	Special Terms and Condition	Annex – II
3	Pre-contract Integrity Pact (IP)	Annex – III

For Technical Clarification- Please Contact: Mr Piyush Paliwal Ph:040-2418 4432  
Email ID: [piyush.paliwal@midhani-india.in](mailto:piyush.paliwal@midhani-india.in)

Submission Of Tender:

Tenders shall be sent by registered post to the following address

To  
DGM (Purchase)  
Mishra Dhatu Nigam Limited  
(A Govt. of India Enterprise)  
Corporate Office, P.O. Kanchanbagh,  
Hyderabad – 500058, India

The Tender cover shall superscribe our Item Description & Tender Number.

For Mishra Dhatu Nigam Limited

*Rakesh*  
29/12/2020  
DGM (Purchase)

राकेश कुमार रोशन / Rakesh Kumar Roushan  
उप महा प्रबंधक, (क्रय) / Dy.Genl.Manager,(Purchase)

## Annex-I

S No.	Item Code	Item Name	Annual Requirement (Approx.)	Specification
1.	PC84-100-00925	Refractory Tundish for VIM 6.5T Furnace	540 Nos	As per attached Annexure-1 A
2.	PC84-100-00908	VIM 600 kg Tundish	100 nos	As per attached Annexure-2 A
3.	PC84-100-01064	VIR Refractory tundish with nozzles 2 nos for each tundish	150 nos	As per attached Annexure-3 A
4.	PC84-100-00080	VIM 2.5T Tundish	240 nos	As per attached Annexure-4 A

## Annexure-1A

### SPECIFICATION FOR VIM 6.5T TUNDISH

<u>PROPERTIES</u>	<u>TUNDISH</u>	<u>NOZZLE &amp; BAFFLE</u>
Max recommended service temp	1800	1800
Bulk Density	2.9 gm/cc Min	2.9 gm/cc Min
Cold Crushing strength	700 – 1100 kg/sq cm	700 – 1100 kg/sq cm
PCE	over Orton cone 38	-----
Thermal Conductivity (W/ m <sup>2</sup> k) at 1000 ± 20°C	3.0max	3.0max
Reheat Change (145C °C to 1500 °C) for 6 hours	± 0.25% max	± 0.25% max
Apparent Porosity	21% max.	18% max.
Al <sub>2</sub> O <sub>3</sub>	92 - 95%	92 - 95%
Fe <sub>2</sub> O <sub>3</sub>	0.8 % max	0.8 % max
SiO <sub>2</sub>	8.0 % max	8.0 % max
MOR at RT	150 kg/sq cm	-
HMOR at 1250° C	75 kg/sq cm	-
SIZE TOLERANCE	± 1.5 mm	± 1.5 mm

- **GUARANTEE:** Material should be as per the specification and free from workmanship defects like cracks, dimensions etc.
- **INDENTOR RESERVES THE RIGHT TO SPLIT THE ORDER AT L1 PRICE.**
- Test certificate to be submitted along with supply. In test certificate all the test result should be clearly mentioned.
- **ACCEPTANCE CRITERIA:** Random inspection may be carried out at supplier's place or at Midhani. If required sample may be sent to authorized national laboratories for cross checking. Accordingly clearance will be given.

## Drawing Details,

REFRACTORY TUNDISH for 6.5 MT VIM FURNACE ALONG WITH 1 KG OF TUNDISH CEMENT AND A NOZZLE AS PER THE FOLLOWING DRAWINGS

- 1) EXIT TUNDISH Drg No. M40 P001- 06-01-A2 Sheet 1 of 2
  - 2) EXIT TUNDISH (Section Drg No. M40 P001- 06-01-A2 Sheet 2 of 2
  - 3) ENTRY TUNDISH Drg No. M40 P001-06-02- A2
  - 4) BAFFLE Drg No. M40 P001-06-03-A4
  - 5) STRAINER BAFFLE Drg No. M40 P001-06-07-A4
  - 6) NOZZLE Dg No. M40 P001-06-06-B4
-

<b>SPECIFICATION OF REFRACTORY TUNDISH FOR VACUUM INDUCTION MELTING FURNACE 600 KG</b>	
<b>1. Max recommended service temp</b>	= 1800° C
<b>2. Physical Properties</b>	
- Bulk Density	= 2.8 – 3.0
- Cold Crushing strength	= 700 – 900 kg/sq cm
- PCE	= over Orton cone 38
Thermal Conductivity (W/ m°k) at 1000°c hot face temp	= 3.0 max
Modulus Rupture (kg/cm <sup>2</sup> ) at RT	= 150 minimum
Mcdulus Rupture (kg/cm <sup>2</sup> ) at 1250°c	= 75 minimum
Reheat Change (%) at 1450 °c for 6 hours	= ± 0.25 max
A.P.	= 21% max.
<b>3. CHEMICAL ANALYSIS</b>	
Al <sub>2</sub> O <sub>3</sub>	= 92 – 95%
Fe <sub>2</sub> O <sub>3</sub>	= 0.08%max
SiO <sub>2</sub>	= 7.8% max
Alkalis	= 0.25% max
<b>4. BASE RAW MATERIAL:</b>	Fused brown Alumina grains. Moulding to be done by Vibro – Compacting press.
<b>5. SIZE TOLERANCE:</b>	± 1.5 minimum
<b>6. WARPAGE:</b>	Max 1.5 mm measured along the diagonal.
<b>1. GUARANTEE:</b>	– Material should be as per the specification and free from workmanship defects like cracks, dimensions etc.
<b>2. DRAWING:</b>	M04P530-06-03-A2 (1 Sheet) and M04P530-06-03-A4 (6 Sheets)
<b>NOTE:</b>	A) EACH SET SHALL CONSIST OF 1 PAIR OF TUNDISH AND 3 NOZZLES. B) TEST CERTIFICATE TO BE SUBMITTED ALONG WITH SUPPLY.

**SPECIFICATION OF VIR 5T FURNACE TUNDISH**

**1. REFRACTORY TUNDISH**

As per our drawing M04P002-11-09-A2.

**2. NOZZLE (FOR REFRACTORY TUNDISH).**

As per our drawing M04P002-11-09-A2.

**SPECIFICATION:**  $Al_2O_3 = 90\%$  min       $Fe_2O_3 = 1.0\%$  max

BD = 3 gm/cm<sup>2</sup>      RUL = 1700 °C

CCS = 950 kg/cm<sup>2</sup>      PLC = ±5 % ( 1500 °C).

Material shall be free from surface defects like Iron/ Slag spots, damaged ends/ corners, bends and bad texture etc. No paint should be used to hide the surface defect.

**PACKING:** Each set (Tundish – 1 No and Nozzle – 2 No's) to be packed in separate wooden boxes with proper cushioning.

**TEST CERTIFICATE:** Test certificate to be submitted along with supply.

**NOTE:**

1. Incomplete offer will not be accepted.
2. The offer for complete set shall only be considered, hence price to be quoted for complete set  
Not for individual items.

**SPECIFICATION FOR VIM-2.5 T TUNDISH**

**Drawing No: M04P501-12-03-B4**

<b><u>SPECIFICATION FOR TUNDISH</u></b>	<b><u>SPECIFICATION FOR NOZZLE AND BAFFLE</u></b>																		
<p><b>1. Max recommended service temp</b> = 1800° C</p> <p><b>2. Physical Properties</b></p> <ul style="list-style-type: none"> <li>- Bulk Density = 2.8 gm/cc Min</li> <li>- Cold Crushing strength = 700 – 900 kg/sq cm</li> <li>- PCE = over orton cone 38</li> <li>-Thermal Conductivity (W/ m°k) at 1000 ± 20°C= 3.0max</li> <li>- Reheat Change (1450 °C to 1500 °C) for 6 hours = ± 0.25% max</li> <li>- A.P. = 21% max.</li> </ul> <p><b>3. CHEMICAL ANALYSIS</b></p> <table border="0"> <tr><td>Al<sub>2</sub>O<sub>3</sub></td><td>=</td><td>92 - 95%</td></tr> <tr><td>Fe<sub>2</sub>O<sub>3</sub></td><td>=</td><td>0.8% max</td></tr> <tr><td>SiO<sub>2</sub></td><td>=</td><td>7.8% max</td></tr> </table> <p><b>4. SIZE TOLERANCE:</b> ± 1.5 minimum</p> <p><b>5. GUARANTEE :-</b> Material should be as per the specification and free from workmanship defects like cracks, dimensions etc.</p>	Al <sub>2</sub> O <sub>3</sub>	=	92 - 95%	Fe <sub>2</sub> O <sub>3</sub>	=	0.8% max	SiO <sub>2</sub>	=	7.8% max	<p><b>1. Max recommended service temp</b> = 1800° C</p> <p><b>2. Physical Properties</b></p> <ul style="list-style-type: none"> <li>- Bulk Density = 2.9 gm/cc Min</li> <li>- Cold Crushing strength = 700 - 1100 kg/sq cm</li> <li>-Thermal Conductivity (W/ m°k) at 800 - 1200°C = 3.0 max</li> <li>- Reheat Change (1450°C to 1500°C ) for 6 hours = ± 0.25% max</li> <li>- A.P. = 18% max.</li> </ul> <p><b>3. CHEMICAL ANALYSIS</b></p> <table border="0"> <tr><td>Al<sub>2</sub>O<sub>3</sub></td><td>=</td><td>88% min</td></tr> <tr><td>Fe<sub>2</sub>O<sub>3</sub></td><td>=</td><td>0.8% max</td></tr> <tr><td>SiO<sub>2</sub></td><td>=</td><td>11% max</td></tr> </table> <p><b>4. SIZE TOLERANCE:</b> ± 1.5 minimum</p> <p><b>5. GUARANTEE:</b> Material should be as per the specification and free from workmanship defects like cracks, dimensions etc.</p>	Al <sub>2</sub> O <sub>3</sub>	=	88% min	Fe <sub>2</sub> O <sub>3</sub>	=	0.8% max	SiO <sub>2</sub>	=	11% max
Al <sub>2</sub> O <sub>3</sub>	=	92 - 95%																	
Fe <sub>2</sub> O <sub>3</sub>	=	0.8% max																	
SiO <sub>2</sub>	=	7.8% max																	
Al <sub>2</sub> O <sub>3</sub>	=	88% min																	
Fe <sub>2</sub> O <sub>3</sub>	=	0.8% max																	
SiO <sub>2</sub>	=	11% max																	
<p><b><u>NOTE:</u></b> TEST CERTIFICATE TO BE SUBMITTED ALONG WITH SUPPLY.</p>																			

VIM 6.5T Tundish Drawing

VIM 6.5T Tundish Drawing

DRG. NO. M 40P001-08-01-A2

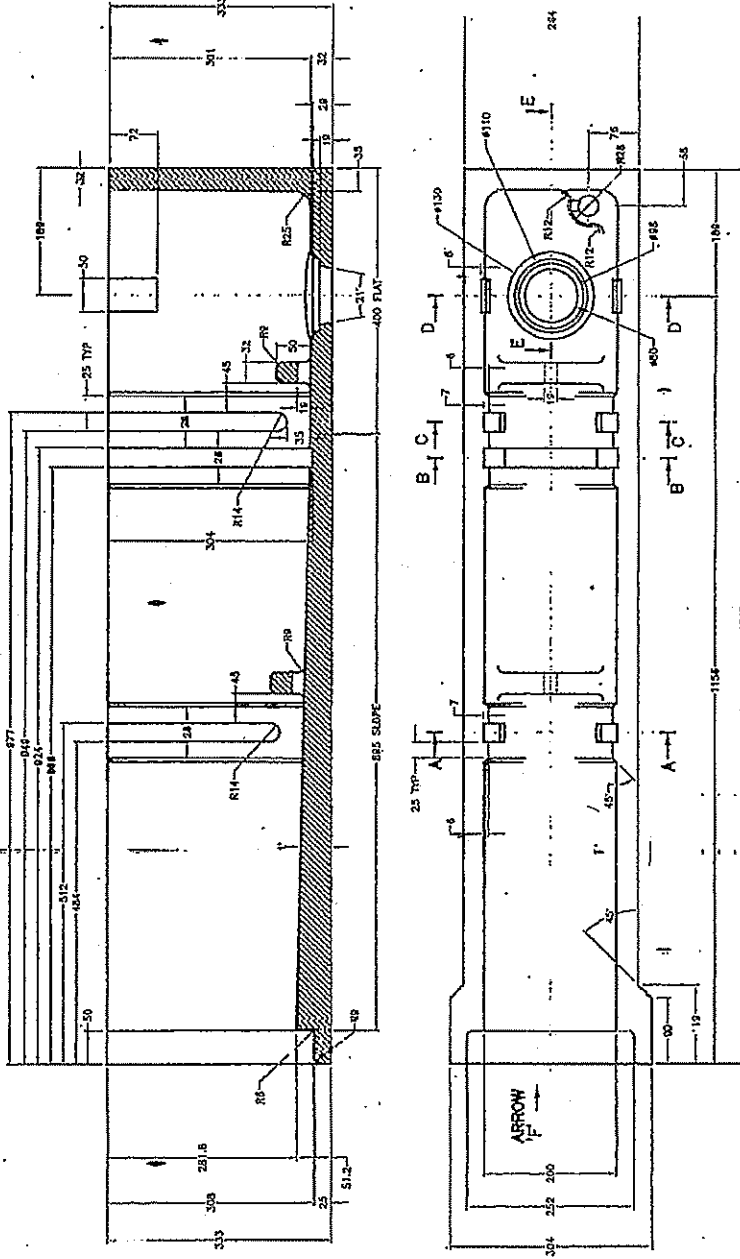

NOTE: BAFFLES SUPPLIED LOOSE.

REV. NO.	DESCRIPTION	MATERIAL	NO. DFT	TOTAL VOLUME	REMARKS
01					
02					
03					
04					
05					
06					
07					
08					
09					
10					
11					
12					
13					
14					
15					
16					
17					
18					
19					
20					
21					
22					
23					
24					
25					
26					
27					
28					
29					
30					
31					
32					
33					
34					
35					
36					
37					
38					
39					
40					
41					
42					
43					
44					
45					
46					
47					
48					
49					
50					
51					
52					
53					
54					
55					
56					
57					
58					
59					
60					
61					
62					
63					
64					
65					
66					
67					
68					
69					
70					
71					
72					
73					
74					
75					
76					
77					
78					
79					
80					
81					
82					
83					
84					
85					
86					
87					
88					
89					
90					
91					
92					
93					
94					
95					
96					
97					
98					
99					
100					

THIS DRAWING IS THE PROPERTY OF M/s MISHRA DHATU NIGAM LTD. AND SHOULD NOT BE GIVEN OR HANDLED OVER OR DIVULGED TO ANY OTHER PERSON WITHOUT THE EXPRESS PERMISSION OF THE COMPANY IN WRITING. THE MATTER GIVEN ON THIS DRAWING IS TO BE TREATED AS STRICTLY CONFIDENTIAL.

1. ALL DIMENSIONS ARE IN MM UNLESS SPECIFIED OTHERWISE.
2. REMOVE BURRS & SHARP CORNERS.
3. REFER TO TOLERANCES SPECIFIED IN DRAWING.
4. FINISH AS SPECIFIED IN DRAWING.
5. DO NOT SCALE DRAWING.
6. ASK IF IN DOUBT.

DESIGNED BY	DATE	APPROVED BY	DATE
S. K. SINGH	21/7/84	S. K. SINGH	21/7/84
MATERIAL: SUPER ALLOY PLANT HYDRABAD			
M/s MISHRA DHATU NIGAM LTD.			
SCALE: AS SHOWN			
TITILE: EXIT TUNDISH 6.5T VIM.			
DRG. NO. M 40P001-08-01-A2			
SHEET 1 OF 2			

FILE IN: MECHANICAL



M40P001-06-01-A2  
 SHEET 2 OF 2

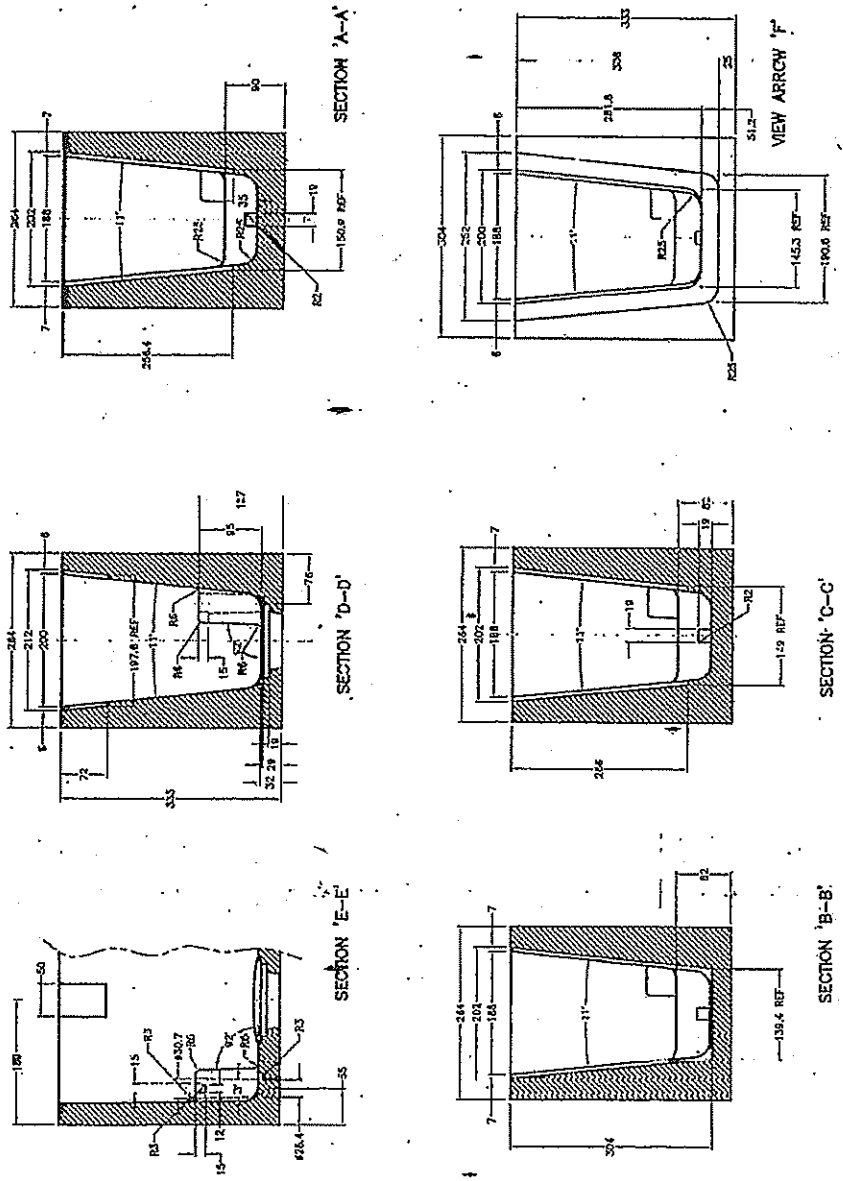

32461	DRG. No.	DESCRIPTION	MATERIAL	No. OF	REMARKS
2007	6.5T VIM		EDPT. HS-3	TOTAL V/Lg.	
<p style="text-align: center;"><b>Mishra Dhatu Nigam Ltd</b>  <b>SUPER ALLOYS PLANT</b>  <b>HYDRABAD</b></p>					
DATE	12/16	APPROVED	BY	DATE	
SCHEMATIC	KAF				
<p style="text-align: center;"><b>EXIT TUNDISH 6.5T VIM</b>  <b>(SECTIONS)</b></p>					
<p>NOTE:          1. ALL DIMENSIONS ARE IN MM. UNLESS OTHERWISE SPECIFIED.          2. FINISH UNLESS OTHERWISE SPECIFIED.          3. SURFACE FINISH IN µm AS PER IS 3496 - 1972.          4. AS PER IS 1502 - 1969 UNLESS OTHERWISE SPECIFIED.          5. STANDARDS FOR MATERIALS TO BE USED IN THE DRAWING SHALL BE AS PER IS 1502 - 1969 UNLESS OTHERWISE SPECIFIED.</p>					
<p>THIS DRAWING IS THE PROPERTY OF MISHRA DHATU NIGAM LTD, AND SHOULD NOT BE GIVEN OR HANDED OVER OR DIVULGED TO ANY OTHER PERSON WITHOUT THE EXPRESS PERMISSION OF THE COMPANY IN WRITING. THE MATTER GIVEN ON THIS DRAWING IS TO BE KEPT AS STRICTLY CONFIDENTIAL.</p>					
No.	DATE	REVISIONS	BY	APPD	REASON



REF. DRG. No.	PRODUCT CODE
BY	APPD
DATE	W.D.No.
No.	REVISION REMARKS

NOTE: 1. ALL DIMENSIONS ARE IN mm U.D.S.  
 2. REMOVE BURRS & SHARP CORNERS  
 3. FREE MEASURE TOLERANCE SHOULD BE AS PER MEDIUM IS:2102 - 1969 U.D.S.

4. FOLLOW RELEVANT INDIAN STANDARDS FOR MANUFACTURE  
 5. DO NOT SCALE DRAWING.  
 6. ASK, IF IN DOUBT.

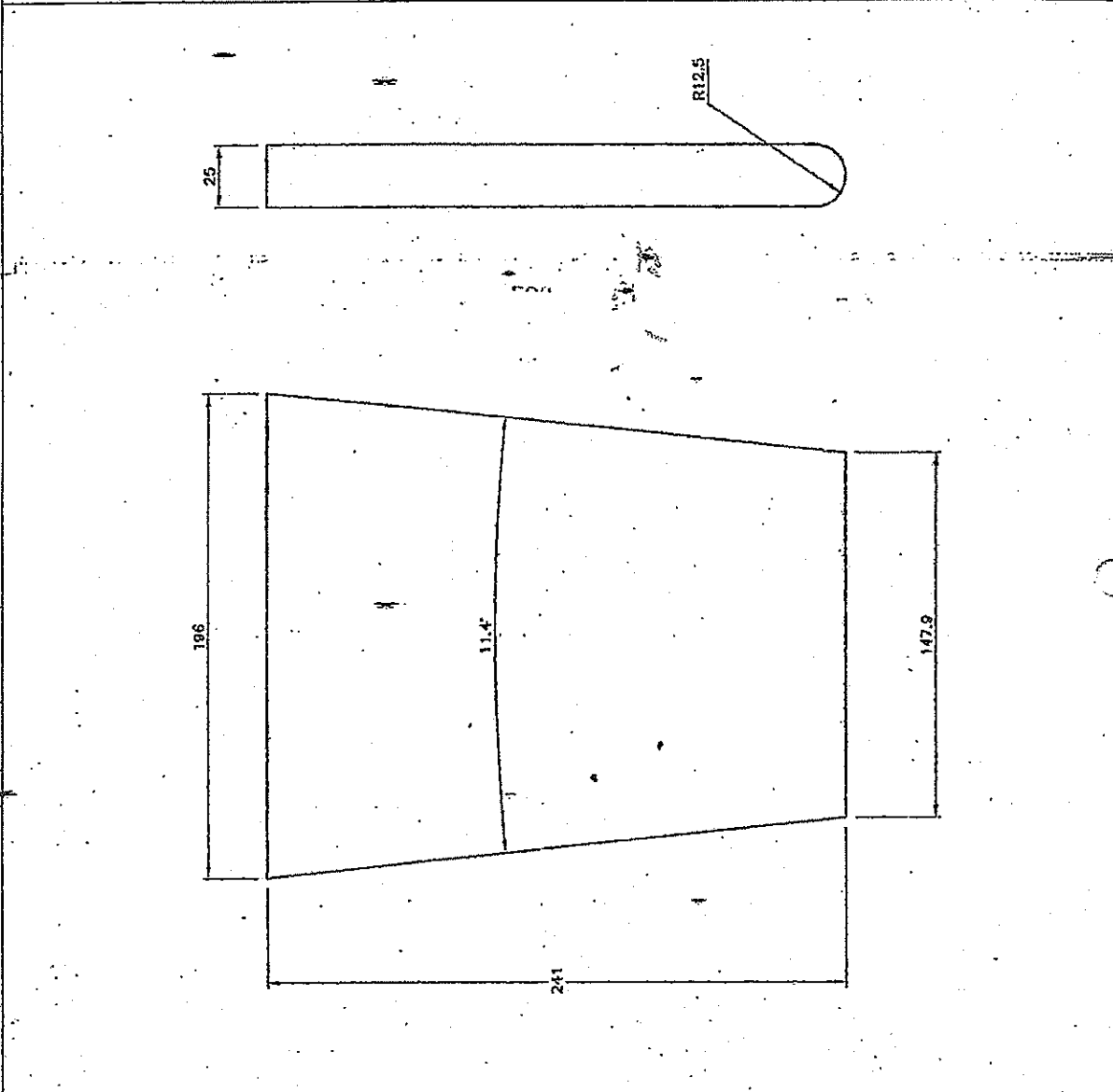

**GENERAL TOLERANCE**  
 UNLESS OTHERWISE STATED  
 ± 1% or 1.5 mm  
 WHICHEVER IS GREATER

THIS DRAWING IS THE PROPERTY OF M/S MISHRA DHATU NIGAM LTD. AND SHOULD NOT BE GIVEN OR HANDED OVER OR DISPLAYED TO ANY OTHER PERSON WITHOUT THE EXPRESS PERMISSION OF THE COMPANY IN WRITING. THE MATTER GIVEN IN THIS DRAWING IS TO BE TREATED AS STRICTLY CONFIDENTIAL.

SL.No.	DRG. No.	DESCRIPTION	MATERIAL	No. of P	PER PCE. WEIGHT kg	TOTAL WEIGHT kg	REMARKS								
EQPT.	6.5T VIM		DEPT.	MS-3		TOTAL Wt. kg									
W.D.No.	06/5/118	 <b>Mishra Dhatu Nigam Ltd</b> <b>SUPER ALLOYS PLANT</b> <b>HYDERABAD</b>		SUPERSEDES											
DESIGNED	NAME			DATE											
SCAND.	KBR			21/06											
APPROVED	chinal			22/06											
			▽▽▽	▽▽	▽	~									
			N1	N2	N3	N4	N5	N6	N7	N8	N9	N10	N11	N12	
			0.025	0.05	0.1	0.3	0.4	0.8	1.6	3.2	6.3	12.5	25	50	
FINISH IF NOT SHOWN			SURFACE FINISH IN μm AS PER IS:696 - 1972												

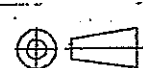
SCALE	N.T.S	TITLE	DRG. No.
		<b>BAFFLE</b>	<b>M40P001-06-03-A4</b>
		<b>6.5T VIM TUNDISH</b>	SHEET 1 OF 1

NOTE: 1. ALL DIMENSIONS ARE IN mm U.O.S.  
 2. REMOVE BURRS & SHARP CORNERS  
 3. FREE MEASURE TOLERANCE SHOULD BE AS PER MEDIUM IS:2102-1988 U.O.S.

4. FOLLOW RELEVANT INDIAN STANDARDS FOR MANUFACTURE  
 5. DO NOT SCALE DRAWING.  
 6. ASK, IF IN DOUBT.

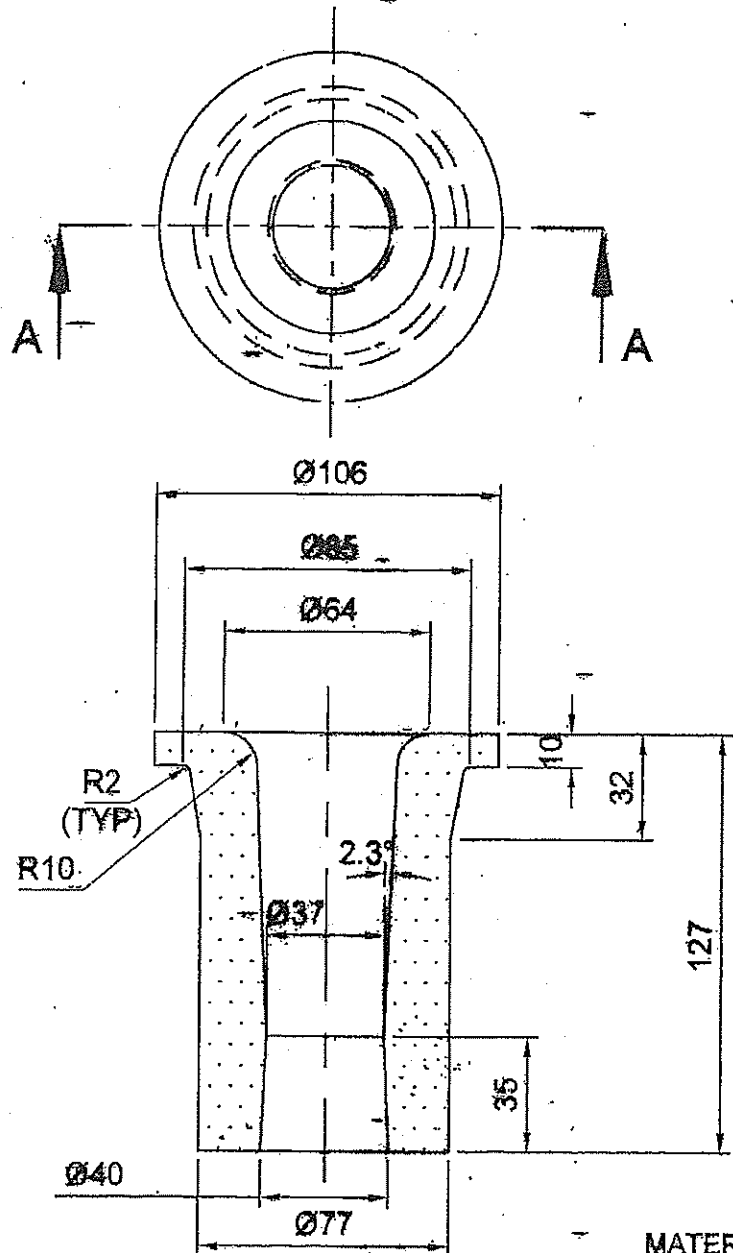

MATERIAL : CUMLOX 201 HF

SECTION - A A

THIS DRAWING IS THE PROPERTY OF M/S. MISHRA DASTI NIGAM LTD. AND SHOULD NOT BE GIVEN OR MANAGED OVER OR DIVULGED TO ANY OTHER PERSON WITHOUT THE EXPRESS PERMISSION OF THE COMPANY IN WRITING. THE MATTER GIVEN ON THIS DRAWING IS TO BE TREATED AS STRICTLY CONFIDENTIAL.

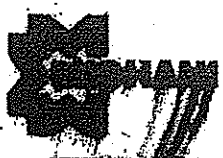
Sl.No.	DRG. No.	DESCRIPTION	MATERIAL	No. OFF	PER PCE	TOTAL WEIGHT	REMARKS																				
	DEPT. 6.5 (VM FCE)		DEPT. MELT SHOP - 3			TOTAL Wt. kg	----																				
W.O. No. 10-5-085		 <b>Mishra Dasti Nigam Ltd</b> <b>SUPER ALLOYS PLANT</b> <b>HYDERABAD</b>																									
DESIGNED	NAME DATE																										
DRAWN	M. MURALI 24/8/2010																										
CHECKED	C.R. MOHAN 8/10																										
APPROVED		<table border="1"> <tr> <td>N1</td><td>N2</td><td>N3</td><td>N4</td><td>N5</td><td>N6</td><td>N7</td><td>N8</td><td>N9</td><td>N10</td><td>N11</td><td>N12</td> </tr> <tr> <td>0.05</td><td>0.05</td><td>0.2</td><td>0.4</td><td>0.6</td><td>1.0</td><td>1.5</td><td>2.0</td><td>2.5</td><td>3.0</td><td>3.5</td><td>4.0</td> </tr> </table>	N1	N2	N3	N4	N5	N6	N7	N8	N9	N10	N11	N12	0.05	0.05	0.2	0.4	0.6	1.0	1.5	2.0	2.5	3.0	3.5	4.0	SUPERSEDES
N1	N2	N3	N4	N5	N6	N7	N8	N9	N10	N11	N12																
0.05	0.05	0.2	0.4	0.6	1.0	1.5	2.0	2.5	3.0	3.5	4.0																
FINISH ▽ IF NOT SHOWN		SURFACE FINISH AS PER IS:695-1972						SUPERSEDED BY																			

SCALE: 1:2	TITLE: <b>NOZZLE 40mm</b> <b>(FOR 6.5 TON VM TUNDISH)</b>	DRG. No.: <b>M40P001-06-08-34</b>
		SHEET 1 OF 1

REF. DRG. No.	SKR 8 613 OF
RELATION	CONFORMING
REMARKS	UNIVERSAL LIMITED
BY	APFD
DATE	
NO.	

NOTE: 1. ALL DIMENSIONS ARE IN mm. U.O.S.  
 2. REMOVE BURRS & SHARP CORNERS  
 3. FREE MEASURE TOLERANCE SHOULD BE AS PER MEDIUM IS:2102 - 1989 U.O.S.

4. FOLLOW RELEVANT INDIAN STANDARDS FOR MANUFACTURE  
 5. DO NOT SCALE DRAWING.  
 6. ASK, IF IN DOUBT.

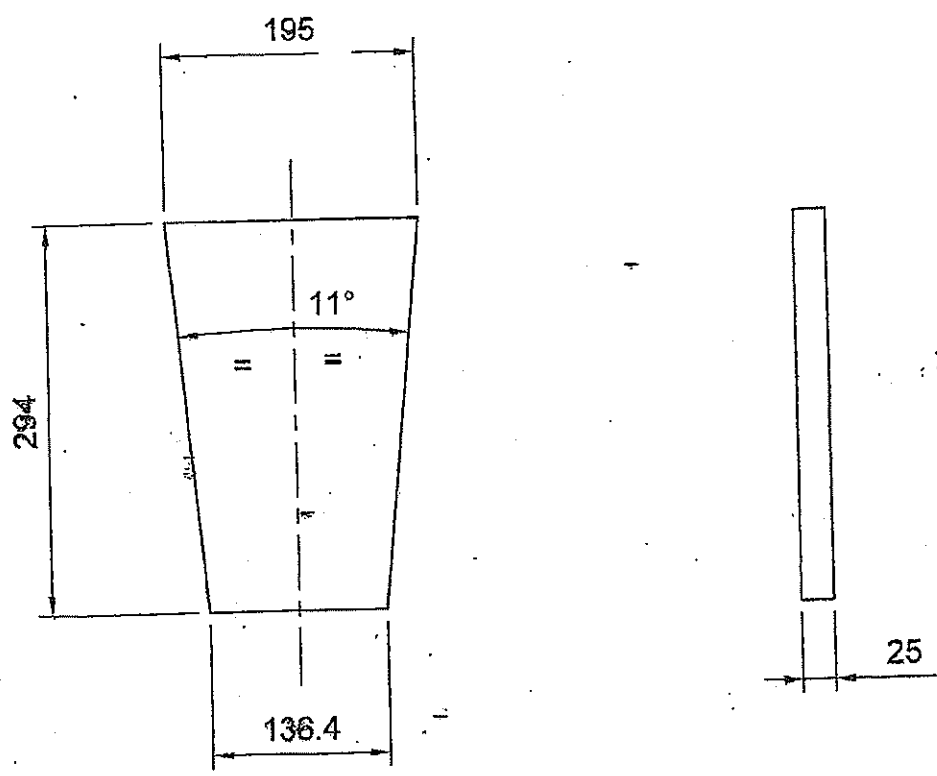

NOTE:-

TOLERANCES:- UNLESS SPECIFIED, GENERAL TOLERANCE OF  $\pm 1.5$  mm OR 1% WHICH EVER IS HIGHER SUBJECT TO A MAX. OF 3mm WILL BE APPLICABLE. ALL DIMENSIONS ARE IN mm.

MATERIAL : CUMILOX 201 HF

THIS DRAWING IS THE PROPERTY OF M/S MISHRA DHATUJANGAM LTD. AND SHOULD NOT BE GIVEN OR HANDED OVER OR DIVULGED TO ANY OTHER PERSON WITHOUT THE EXPRESS PERMISSION OF THE COMPANY IN WRITING. THE MATTER GIVEN ON THIS DRAWING IS TO BE TREATED AS STRICTLY CONFIDENTIAL.

SI No.	DRG. No.	DESCRIPTION	MATERIAL	No. OF-	PER CCE. WEIGHT kg.	TOTAL WEIGHT kg.	REMARKS								
	EQPT. 6.5 T VIM FEC		DEPT. MELT SHOP - 3												
W.O. No. 10-5-065			<b>Mishra Dhatu Nigam Ltd</b> <b>SUPER ALLOYS PLANT</b> <b>HYDERABAD</b>												
DESIGNED	NAME							DATE							
DRAWN	M MURALI							24/8/2010							
CHECKED	G. S. KHAN							24/8/10							
APPROVED			N1	N2	N3	N4	N5	N6	N7	N8	N9	N10	N11	N12	SUPERSEDES
			0.025	0.05	0.1	0.2	0.4	0.8	1.6	3.2	6.3	12.5	25	50	SUPERSEDED BY
FINISH $\nabla$ IF NOT SHOWN		SURFACE FINISH IN $\mu$ m AS PER IS:896 - 1972													
SCALE 1:5	TITLE		DRG. No.												
	STRAINER BAFFLE		M40P001 - 06 - 07 - AA												
	(FOR 6.5TON. VIM TUNDISH)		SHEET 1 OF 1												

VIR51 Tundish Drg.

REV. NO. 1  
 DATE 24-09-11  
 MO-PRJ-11-2004PDM

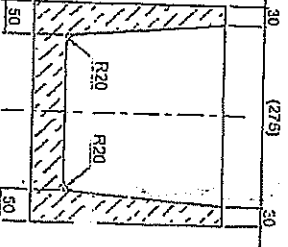
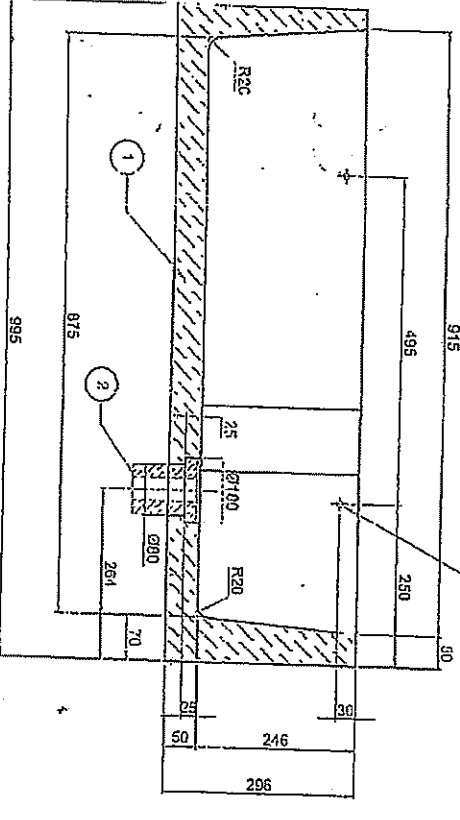
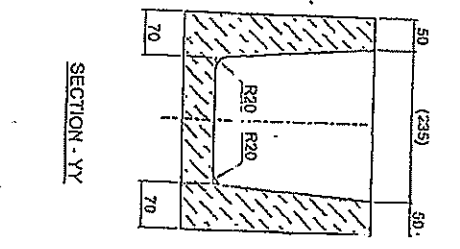
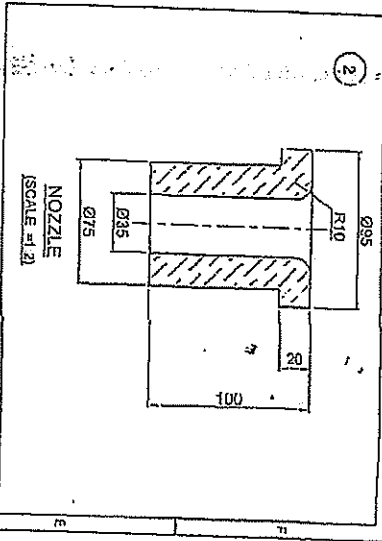
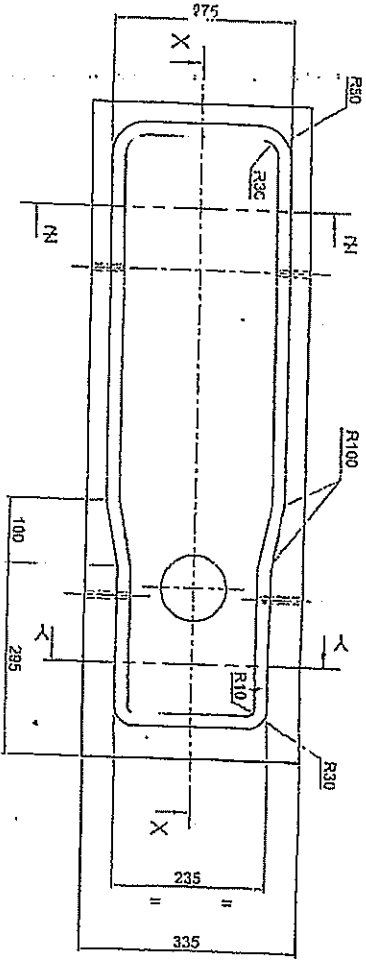

2 - HOLES, Ø10  
 THRU AS SHOWN

\* MATERIAL COMPOSITION

ANG - 50% max  
 Fe-C - 1.0% max  
 Si-C - 0.25% max  
 P-C - 0.02% max  
 S-C - 0.01% max

SECTION - XX

SECTION - ZZ

NO.	DATE	REVISED	BY	APPD
1				

THIS DRAWING IS THE PROPERTY OF M/S NISHA DRATU NIGAM LTD. AND SHOULD NOT BE GIVEN OR HANDED OVER OR DIVULGED TO ANY OTHER PERSON WITHOUT THE EXPRESS PERMISSION OF THE COMPANY IN WRITING. THE MATTER GIVEN ON THIS DRAWING IS TO BE TREATED AS STRICTLY CONFIDENTIAL.

- 1. DIMENSIONS ARE IN MM. UNLESS SPECIFIED OTHERWISE.
- 2. FINISH SURFACE SHOULD BE AS PER NISHA DRATU NIGAM LTD. SPECIFICATION.
- 3. ALL DIMENSIONS SHOULD BE TAKEN FROM THE CENTERLINE UNLESS SPECIFIED OTHERWISE.
- 4. SURFACE FINISH SHALL BE AS PER NISHA DRATU NIGAM LTD. SPECIFICATION.
- 5. ALL DIMENSIONS SHOULD BE TAKEN FROM THE CENTERLINE UNLESS SPECIFIED OTHERWISE.
- 6. SURFACE FINISH SHALL BE AS PER NISHA DRATU NIGAM LTD. SPECIFICATION.

NO.	REVISED	DATE	NOZZLE	
			DESCRIPTION	REMARKS
1			NOZZLE	NOZZLE
<p>NOZZLE</p> <p>REFRACTORY TUNDISH</p> <p>REFRACTORY TUNDISH</p> <p>REFRACTORY TUNDISH</p> <p>REFRACTORY TUNDISH</p>				

**Mishra Dhatu Nigam Ltd**  
 SUPER ALLOYS PLANT  
 HYDERABAD

REFRACTORY TUNDISH

MO-PRJ-11-09-A2

# VIM 2.5T Tundish Drawing

REF. DRG. NO. :- SK. NO. R 2012 OF CARBORUNDUM  
 UNIVERSAL LTD. MADRAS, INDIA  
 DIMN.  $\phi$  30 WAS  $\phi$  35

ASK IF IN DOUBT REMOVE BURRS & SHARP CORNERS FREE MEASURE TOLERANCE SHOULD BE AS PER MEDIUM IS : 2102-1969 UNLESS STATED OTHERWISE  
 DON'T SCALE DRAWING ALL DIMENSIONS ARE IN mm U. S.

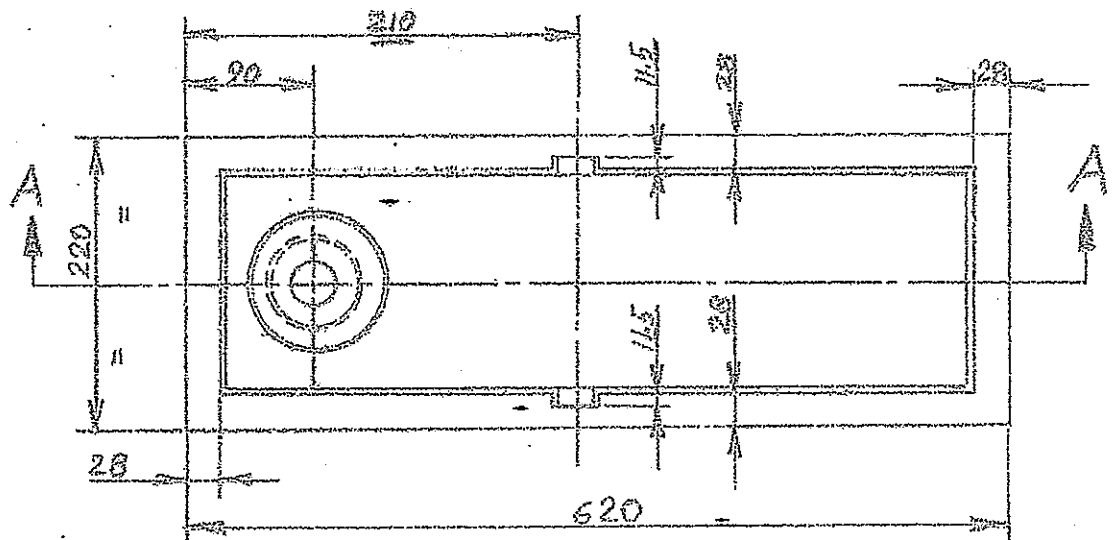
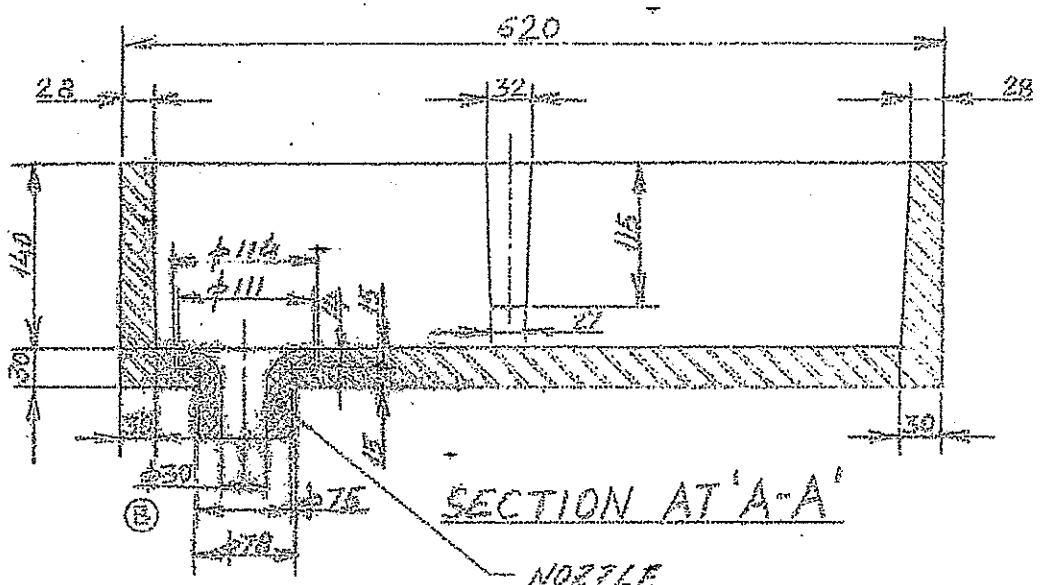

MATL: HIGH ALUMINA (85% Al<sub>2</sub>O<sub>3</sub>)

THIS DRAWING IS THE PROPERTY OF M/S. MISHRA DHATU NIGAM LTD. AND SHOULD NOT BE GIVEN OR HANDED OVER OR DIVULGED TO ANY OTHER PERSON WITHOUT THE EXPRESS PERMISSION OF THE COMPANY IN WRITING. THE MATTER GIVEN ON THIS DRAWING IS TO BE TREATED AS STRICTLY CONFIDENTIAL.

SL. No.	DRG. No.	DESCRIPTION	MATERIAL	NO. OFF.	PER PCE	TOTAL	REMARKS	
EQPT.	VIM FURNACE	DEPT. MELT SHOP - 2			WEIGHT Kg.	TOTAL Wt Kg:		
W.O. No.	33/5/333							
DESIGNED								
DRAWN/TCD.								
CHKD/COMP.								
APPROVED								
FINISH $\nabla$ IF NOT SHOWN		SURFACE FINISH IN $\mu$ m AS PER IS: 698-1972						
SCALE	1:5	TITLE	TUNDISH				DRG. No.	MO4P501-12-03-B4
							SHEET 1 OF 1	



**Mishra Dhatu Nigam Ltd**  
 SUPER ALLOYS PROJECT  
 HYDERABAD

N1	N2	N3	N4	N5	N6	N7	N8	N9	N10	N11	N12
0.025	0.05	0.1	0.2	0.4	0.8	1.6	3.2	6.3	12.5	25	50

SUPERSEDES  
 SUPERSEDED BY

10

VITTI SVARTY. WILLOW & COMPANY LTD.

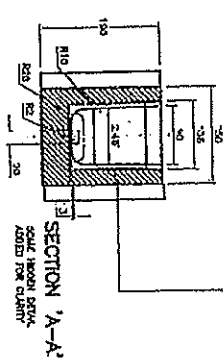
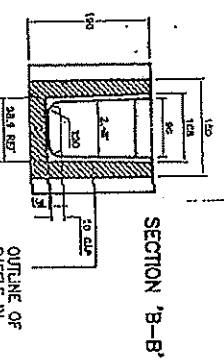
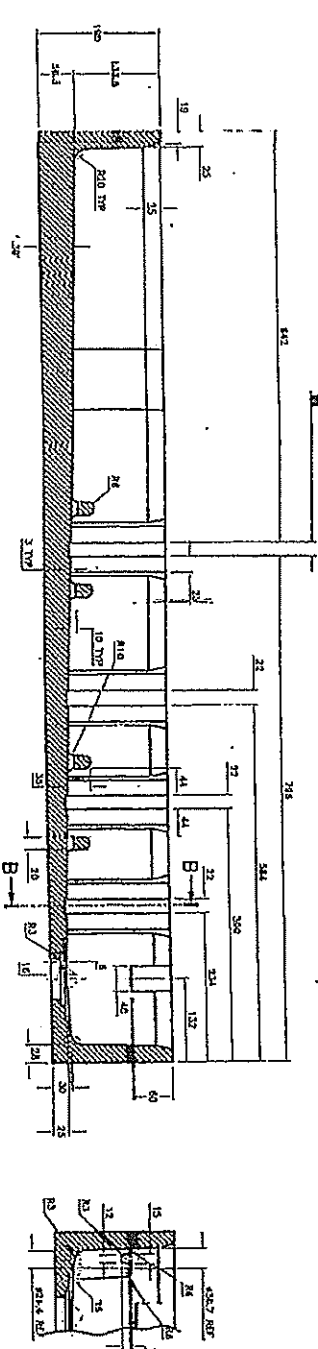
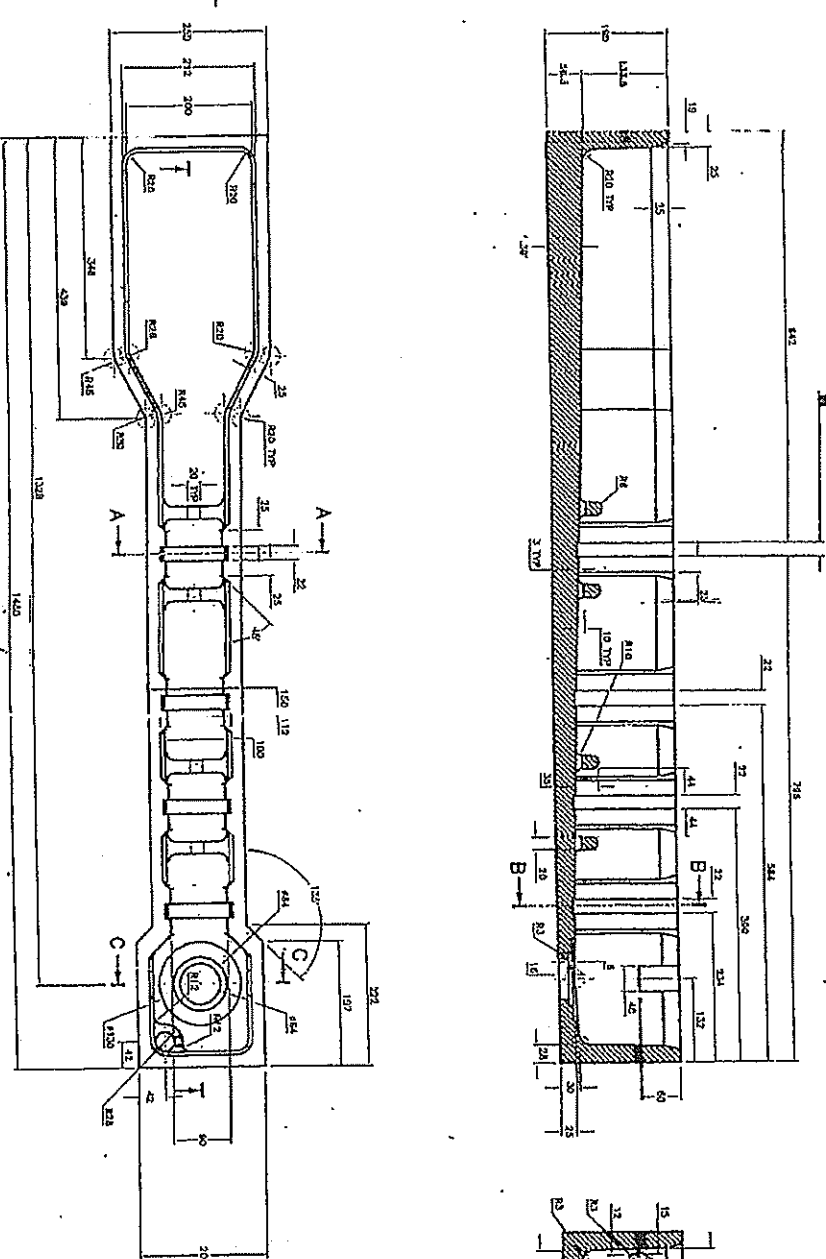

(DIMENSIONS IN METRIC - ANGULAR DIMENSIONS IN DEGREE DEGREES)

NO. 104P530-08-03-A2

NO.	DATE	VALUES	REVISIONS

THIS DRAWING IS THE PROPERTY OF M/S MISHRA DATU NIGAM LTD. AND SHOULD NOT BE GIVEN OR DIVULGED TO ANY OTHER PERSON WITHOUT THE EXPRESS PERMISSION OF THE COMPANY IN WRITING. THE MATTER GIVEN ON THIS DRAWING IS TO BE TREATED AS STRICTLY CONFIDENTIAL.

NOTE: ALL DIMENSIONS ARE IN mm UNLESS SPECIFIED OTHERWISE. DIMENSIONS SHOULD BE AS PER HINDI STANDARD IS: 1985 UNLESS OTHERWISE SPECIFIED FOR MANUFACTURE.

STATE	DOC. NO.	DESCRIPTION	MATERIAL	REV.	DATE	REMARKS

**MISHRA DATU NIGAM LTD.**  
**HYDERABAD**  
**Mishra Datu Nigam Ltd.**  
**SUPER ALLOYS PLANT**

TUNDIRISH 800 kg. VIM  
 M04P530-08-03-A2



21  
AS

NOTE:  
1. ALL DIMENSIONS ARE IN mm U.O.S.  
2. REMOVE BURRS & SHARP CORNERS  
3. FREE MEASURE TOLERANCE SHOULD BE AS PER MEDIUM IS:2102 - 1969 U.O.S.

4. FOLLOW RELEVANT INDIAN STANDARDS FOR MANUFACTURE  
5. DO NOT SCALE DRAWING  
6. ASK, IF IN DOUBT.

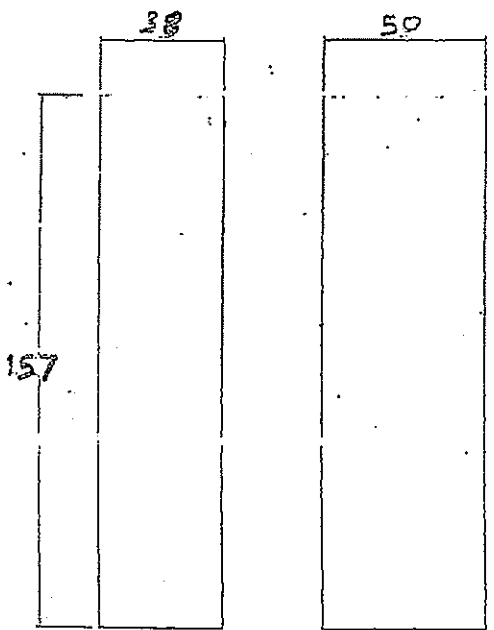

GENERAL TOLERANCE  
UNLESS OTHERWISE STATED  
± 1% or 1.5mm  
WHICHEVER IS GREATER

THIS DRAWING IS TO BE TREATED AS STRICTLY CONFIDENTIAL. THE SAME MUST BE KEPT BY WINNING THE MATERIAL GIVEN ON

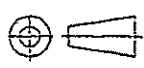
Sl.No.	DRG. No.	DESCRIPTION	MATERIAL	No. OFF	PER PCE. (TOTAL WEIGHT - kg)	REMARKS																																	
EQPT.	600KG VIM		DEPT. MELT SHOP - 2		TOTAL Wt. kg																																		
W.O.No.	06/5/118		<b>Mishra Dhate Nigam Ltd</b> <b>SUPER ALLOYS PLANT</b> <b>HYDERABAD</b>																																				
DESIGNED	NAME						DATE																																
SCAND	KBR						21/9/06																																
CHK/COMP	c.kim						22/9/06																																
APPROVED		25/09/06	<table border="1"> <tr> <td>▽▽▽</td> <td>▽▽</td> <td>▽</td> <td>▽</td> <td>~</td> </tr> <tr> <td>N1</td> <td>N2</td> <td>N3</td> <td>N4</td> <td>N5</td> </tr> <tr> <td>0.025</td> <td>0.05</td> <td>0.1</td> <td>0.2</td> <td>0.4</td> </tr> <tr> <td>N6</td> <td>N7</td> <td>N8</td> <td>N9</td> <td>N10</td> </tr> <tr> <td>0.8</td> <td>1.6</td> <td>3.2</td> <td>6.3</td> <td>12.5</td> </tr> <tr> <td>N11</td> <td>N12</td> <td colspan="3"></td> </tr> <tr> <td>25</td> <td>50</td> <td colspan="3"></td> </tr> </table>	▽▽▽	▽▽	▽	▽	~	N1	N2	N3	N4	N5	0.025	0.05	0.1	0.2	0.4	N6	N7	N8	N9	N10	0.8	1.6	3.2	6.3	12.5	N11	N12				25	50				SUPERSEDES  SUPERSEDED BY
▽▽▽	▽▽	▽	▽	~																																			
N1	N2	N3	N4	N5																																			
0.025	0.05	0.1	0.2	0.4																																			
N6	N7	N8	N9	N10																																			
0.8	1.6	3.2	6.3	12.5																																			
N11	N12																																						
25	50																																						
FINISH <input checked="" type="checkbox"/> IF NOT SHOWN		SURFACE FINISH IN μm AS PER IS:696 - 1972																																					
SCALE 1:2	TITLE		DRG. No.																																				
	<b>HOLD DOWN BLOCK</b> <b>600kg VIM TUNDISH</b>		<b>M04P530-06-03-A4</b>																																				
		SHEET 2		OF 7																																			

(12)  
1a

REF. DRG. No.	PRODUCT CODE
71V	
BY	APFD
REVISION	REMARKS
No.	DATE
W.D.No.	

NOTE: 1. ALL DIMENSIONS ARE IN mm U.S.S.  
2. REMOVE BURRS & SHARP CORNERS  
3. FREE MEASURE TOLERANCE SHOULD BE AS PER MEDIUM IS:2102 - 1969 U.S.S.

4. FOLLOW RELEVANT INDIAN STANDARDS FOR MANUFACTURE  
5. DO NOT SCALE DRAWING.  
6. ASK, IF IN DOUBT.

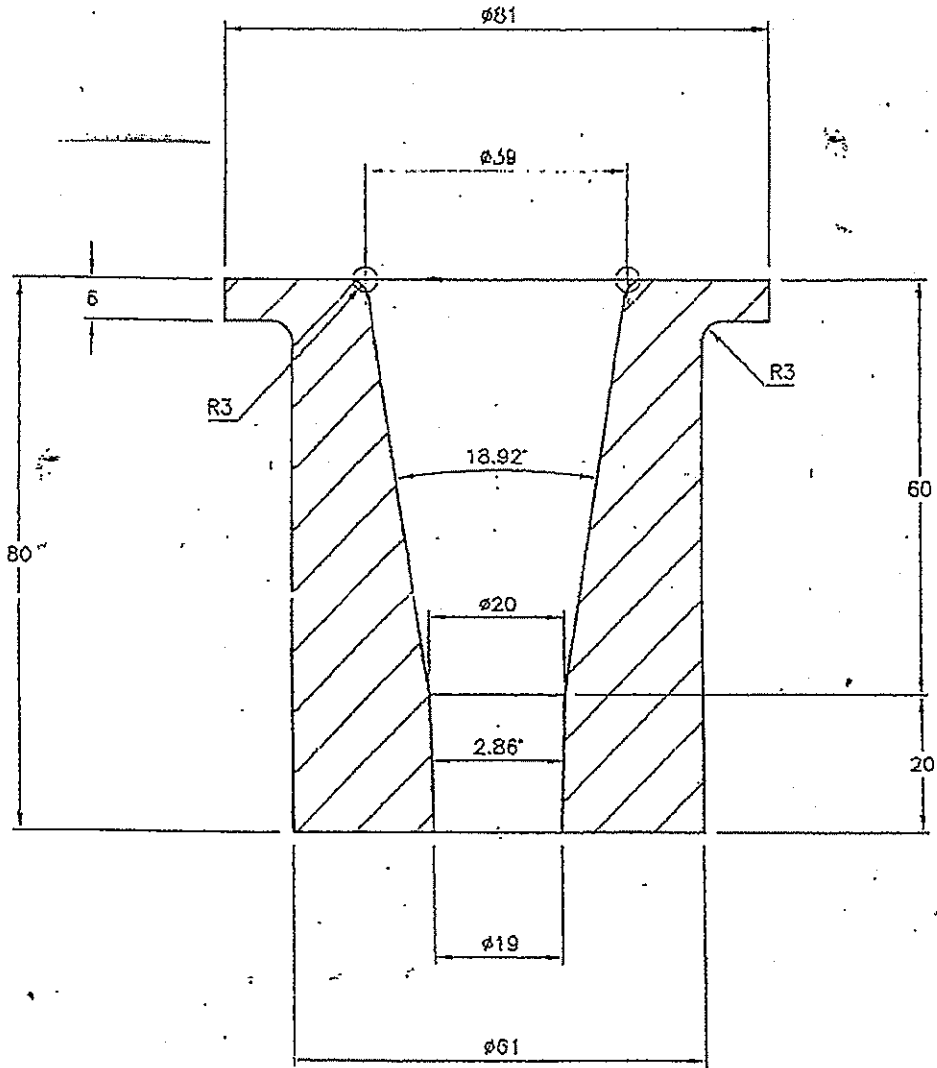

GENERAL TOLERANCE  
UNLESS OTHERWISE STATED  
± 1% OR 1.5 mm

THIS DRAWING IS THE PROPERTY OF M/s MISHRA DHATU NIGAM L.D. AND SHOULD NOT BE GIVEN OR HANDED OVER OR DIVULGED TO ANY OTHER PERSON WITHOUT THE EXPRESS PERMISSION OF THE COMPANY IN WRITING. THE MATTER GIVEN ON THIS DRAWING IS TO BE TREATED AS STRICTLY CONFIDENTIAL.

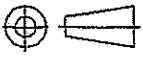
Sl.No.	DRG. No.	DESCRIPTION	MATERIAL	No. OFF	PER PCE.	TOTAL WEIGHT kg.	REMARKS								
EQPT.	600KG VIM		DEPT.	MELT SHOP - 2		TOTAL Wt. kg									
W.D.No.	06/5/118														
DESIGNED	NAME	DATE	 <b>Mishra Dhatu Nigam Ltd</b> <b>SUPER ALLOYS PLANT</b> <b>HYDERABAD</b>												
SLAVD	KBR	21/06													
CHK/COMP	NAME	DATE	▽▽▽	▽▽	▽	▽	~								
APPROVED	L.A.S	25/06	N1	N2	N3	N4	N5	N6	N7	N8	N9	N10	N11	N12	SUPERSEDES
			0.025	0.05	0.1	0.2	0.4	0.8	1.6	3.2	6.3	12.5	25	50	SUPERSEDED BY
FINISH <input checked="" type="checkbox"/> IF NOT SHOWN			SURFACE FINISH IN μm AS PER IS:696 - 1972												
SCALE	1:1	TITLE	<b>NOZZLE 19 DIA.</b> <b>600 kg VIM TUNDISH.</b>												
		DRG. No.	<b>M04P530-06-03-A4</b>												
		SHEET	3	OF	7										

43

REF. DRG. No.	PRODUCT CODE
71V	
BY	APPD
REVISION	REMARKS
No.	DATE
V	U

NOTE: 1. ALL DIMENSIONS ARE IN mm U.D.S.  
 2. REMOVE BURRS & SHARP CORNERS  
 3. FREE MEASURE TOLERANCE SHOULD BE AS PER MEDIUM IS:2102 - 1969 U.D.S.

4. FOLLOW RELEVANT INDIAN STANDARDS FOR MANUFACTURE  
 5. DO NOT SCALE DRAWING.  
 6. ASK, IF IN DOUBT.

16

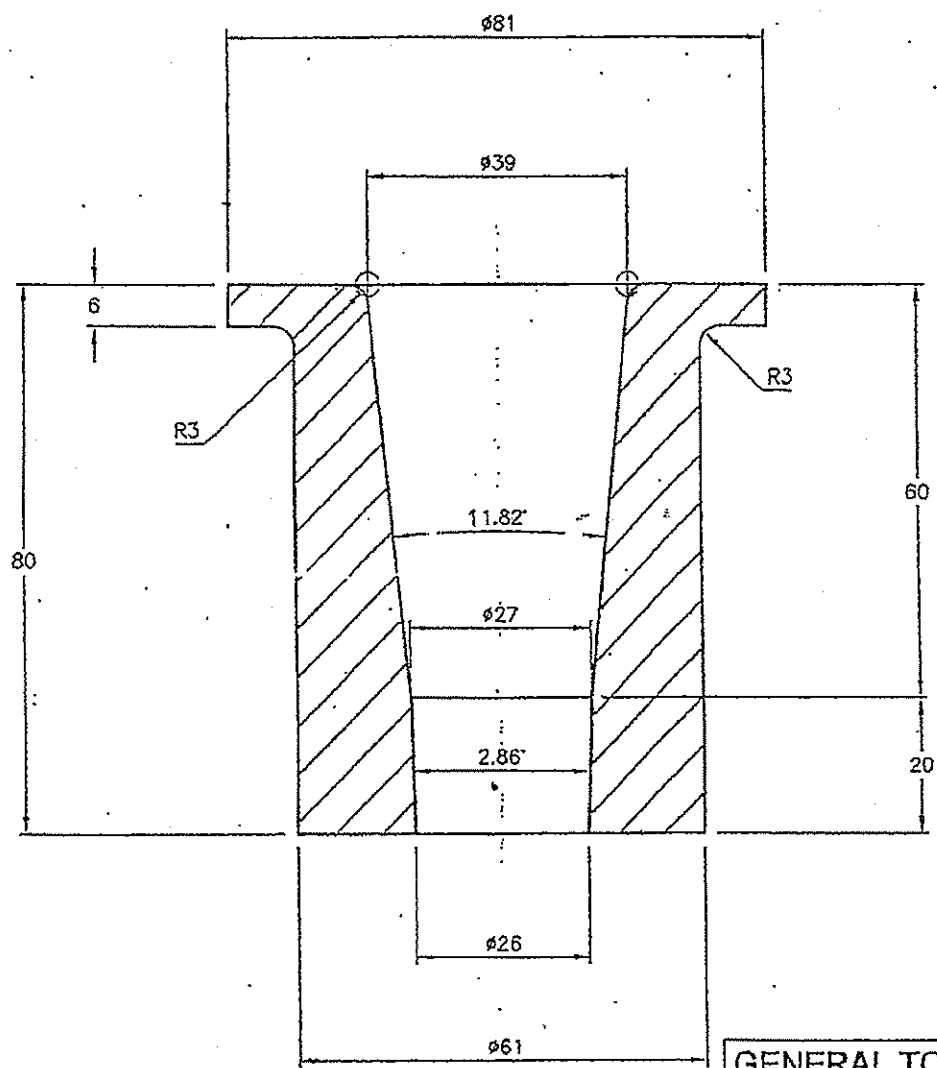

**GENERAL TOLERANCE**  
 UNLESS OTHERWISE STATED  
 ± 1% OR 1.5 mm

THIS DRAWING IS THE PROPERTY OF M/s MISHRA DHATU NIGAM LTD. AND SHOULD NOT BE GIVEN OR HANDED OVER OR DIVULGED TO ANY OTHER PERSON WITHOUT THE EXPRESS PERMISSION OF THE COMPANY IN WRITING. THE MATTER GIVEN ON THIS DRAWING IS TO BE TREATED AS STRICTLY CONFIDENTIAL.

Sl.No.	DRG. No.	DESCRIPTION	MATERIAL	No. OFF	PER PCE.	TOTAL WEIGHT kg.	REMARKS									
EQPT.	600KG VIM		DEPT.	MELT SHOP - 2		TOTAL Wt. kg										
W.D.No.	06/5/11B															
DESIGNED	NAME	DATE	 <b>Mishra Dhatu Nigam Ltd</b> <b>SUPER ALLOYS PLANT</b> <b>HYDERABAD</b>													
SCAND:	KBR	21/06														
CHKD/CBMP			SUPERSEDES													
APPROVED			N1	N2	N3	N4	N5	N6	N7	N8	N9	N10	N11	N12	SUPERSEDED BY	
			0.025	0.05	0.1	0.2	0.4	0.8	1.6	3.2	6.3	12.5	25	50		
FINISH	IF NOT SHOWN		SURFACE FINISH IN μm AS PER IS:696 - 1972													
SCALE	1:1	TITLE	<b>NOZZLE 26 DIA.</b> <b>600 Kg VIM TUNDISH</b>													
		DRG. No.	<b>M04P530-06-03-A4</b>													
		SHEET	4											OF	7	

NOTE: 1. ALL DIMENSIONS ARE IN mm U.S.S.  
 2. REMOVE BURRS & SHARP CORNERS  
 3. FREE MEASURE TOLERANCE SHOULD BE AS PER MEDIUM IS:2102 - 1969 U.S.S.  
 4. FOLLOW RELEVANT INDIAN STANDARDS FOR MANUFACTURE  
 5. DO NOT SCALE DRAWING.  
 6. ASK, IF IN DOUBT.

REF. DRG. No.		PRODUCT CODE	
BY		APPD	
REVISION		REMARKS	
No.	DATE	V.D. No.	

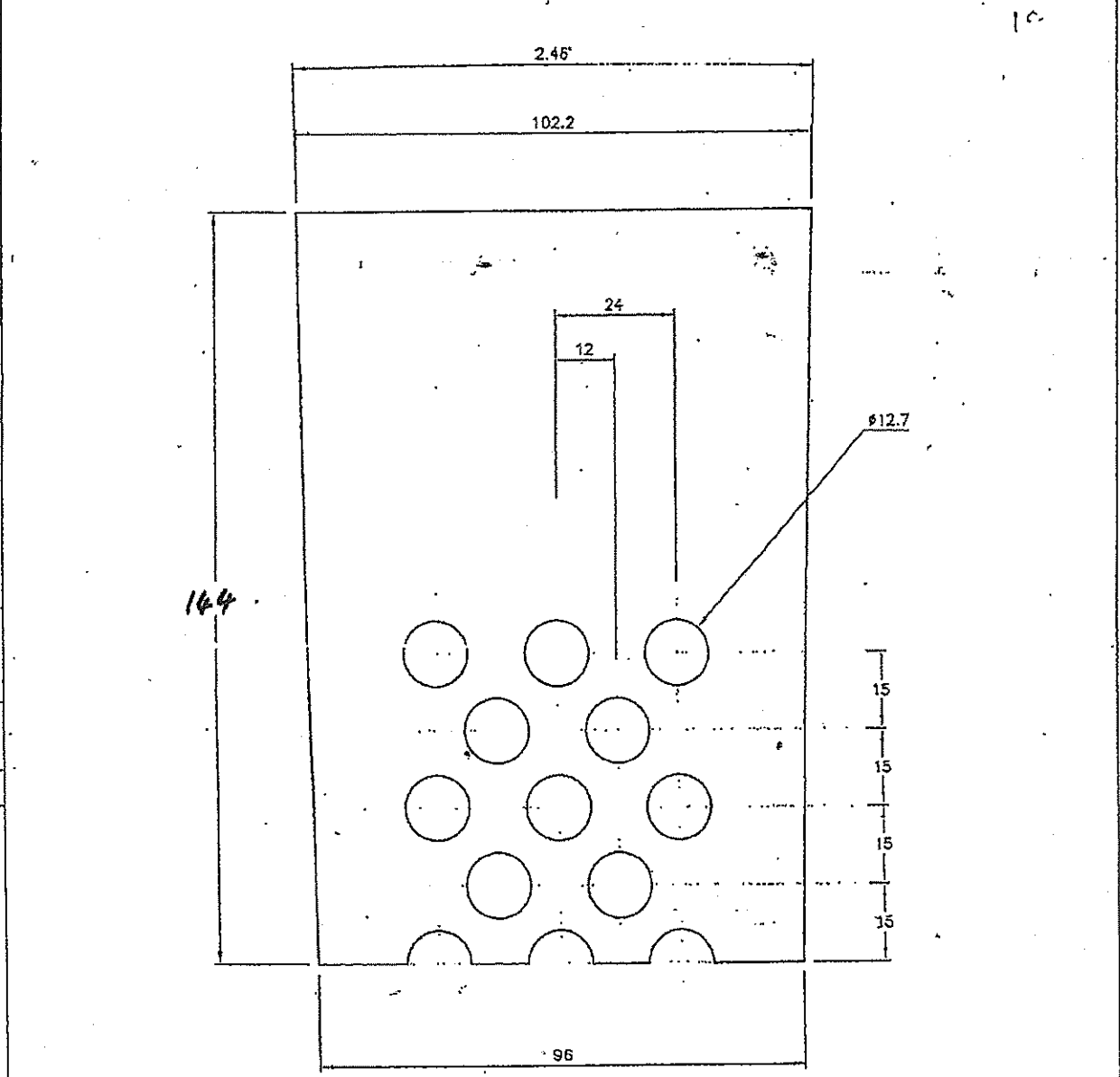

20mm THICK

GENERAL TOLERANCE  
 UNLESS OTHERWISE STATED  
 ± 1% or 1.5mm  
 WHICHEVER IS GREATER

THIS DRAWING IS THE PROPERTY OF M/s MISHRA DHATU NIGAM LTD. AND SHOULD NOT BE GIVEN OR HANDED OVER OR DIVULGED TO ANY OTHER PERSON WITHOUT THE EXPRESS PERMISSION OF THE COMPANY IN WRITING. THE MATTER GIVEN ON THIS DRAWING IS TO BE TREATED AS STRICTLY CONFIDENTIAL.

Sl.No.	DRG. No.	DESCRIPTION	MATERIAL	No. OFF	PER PCE.	TOTAL WEIGHT kg.	REMARKS								
EQPT.	600KG VIM		DEPT.	MELT SHOP - 2		TOTAL Wt. kg									
W.D.No.	06/5/118		<b>Mishra Dhatu Nigam Ltd</b> <b>SUPER ALLOYS PLANT</b> <b>HYDERABAD</b>					SUPERSEDES							
DESIGNED	NAME								DATE	▽▽▽	▽▽	▽	~		
SCAND.	<i>A.K.R.</i>								<i>25/06</i>	NI	N2	N3	N4	N5	N6
APPROVED	<i>A.C.</i>	<i>23/06</i>	0.025	0.05	0.1	0.2	0.4	0.8	1.6	3.2	6.3	12.5	25	50	SUPERSEDED BY
FINISH	IF NOT SHOWN		SURFACE FINISH IN μm AS PER IS:696 - 1972												
SCALE	--	TITLE	<b>STRAINER BAFFLE 600Kg</b> <b>VIM TUNDISH</b>										DRG. No.	<b>M 04P530-06-03-A4</b>	
												SHEET 5	OF 7		

(3)

NOTE: 1. ALL DIMENSIONS ARE IN mm U.O.S.  
 2. REMOVE BURRS & SHARP CORNERS  
 3. FREE MEASURE TOLERANCE SHOULD BE AS PER MEDIUM IS:2102 - 1969 U.O.S.

4. FOLLOW RELEVANT INDIAN STANDARDS FOR MANUFACTURE  
 5. DO NOT SCALE DRAWING.  
 6. ASK, IF IN DOUBT.

REF. DRG. No.	PRODUCT CODE
BY	APPD
REVISION	REMARKS
No.	DATE
V.O.No.	

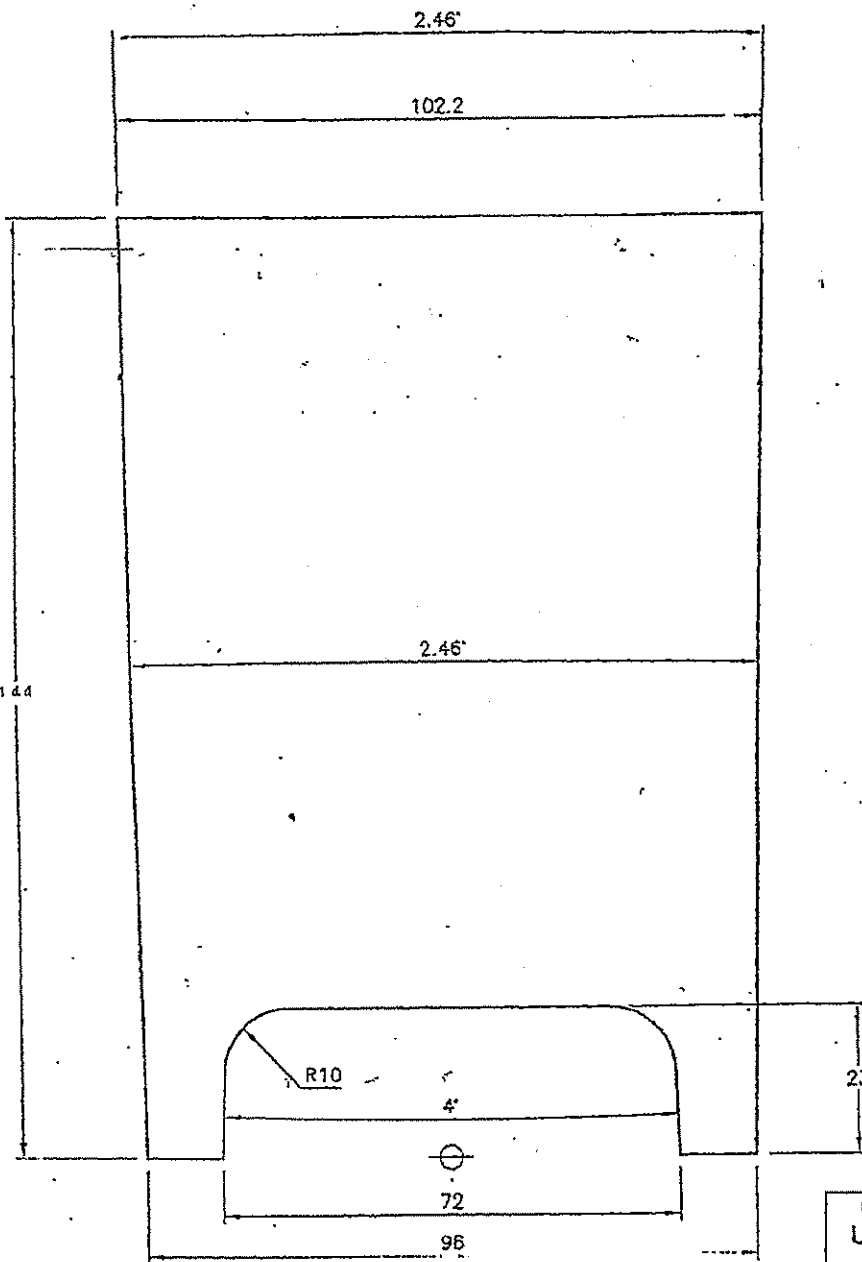

20 mm THICK

GENERAL TOLERANCE  
 UNLESS OTHER STATED  
 ± 1% or 1.5 mm  
 WHICHEVER IS FREAT

THIS DRAWING IS THE PROPERTY OF M/s MISHRA DHATU NIGAM LTD. AND SHOULD NOT BE GIVEN OR HANDED OVER OR DIVULGED TO ANY OTHER PERSON WITHOUT THE EXPRESS PERMISSION OF THE COMPANY IN WRITING. THE MATTER GIVEN ON THIS DRAWING IS TO BE TREATED AS STRICTLY CONFIDENTIAL.

Sl.No.	DRG. No.	DESCRIPTION	MATERIAL	No. OFF	PER PCE	TOTAL	REMARKS
	EQPT.	600KG VIM	DEPT.	MELT SHOP - 2	WEIGHT kg.	TOTAL Wt. kg	
W.O.No.		Mishra Dhatu Nigam Ltd		SUPER ALLOYS PLANT HYDERABAD			
DESIGNED	NAME	DATE	SUPERSEDES				
SCAND	KBR	21/9/06	SUPERSEDED BY				
COMP		22/10/06					
APPROVED	A.C.	25/07/06					
FINISH		SURFACE FINISH IN μm AS PER IS:696 - 1972					
SCALE 1:1		TITLE			DRG. No.		
		UNIVERSAL BAFFLE			M04P530-06-03-A4		
		600 kg: VIM TUNDISH			SHEET 6 OF 7		

10

REF. DRG. No. \_\_\_\_\_  
 PRODUCT CODE \_\_\_\_\_  
 MKU \_\_\_\_\_  
 BY APPD \_\_\_\_\_  
 REVISION REMARKS \_\_\_\_\_  
 V.D.No. \_\_\_\_\_  
 DATE \_\_\_\_\_  
 No. \_\_\_\_\_  
 THIS DRAWING IS THE PROPERTY OF M/s MISHRA DHATU NIGAM LTD. AND SHOULD NOT BE GIVEN OR HANDED OVER OR DIVULGED TO ANY OTHER PERSON WITHOUT THE EXPRESS PERMISSION OF THE COMPANY IN WRITING. THE MATTER GIVEN ON THIS DRAWING IS TO BE TREATED AS STRICTLY CONFIDENTIAL.

NOTE: 1. ALL DIMENSIONS ARE IN mm U.D.S.  
 2. REMOVE BURRS & SHARP CORNERS  
 3. FREE MEASURE TOLERANCE SHOULD BE AS PER MEDIUM IS:2102 - 1969 U.D.S.  
 4. FOLLOW RELEVANT INDIAN STANDARDS FOR MANUFACTURE  
 5. DO NOT SCALE DRAWING.  
 6. ASK, IF IN DOUBT.

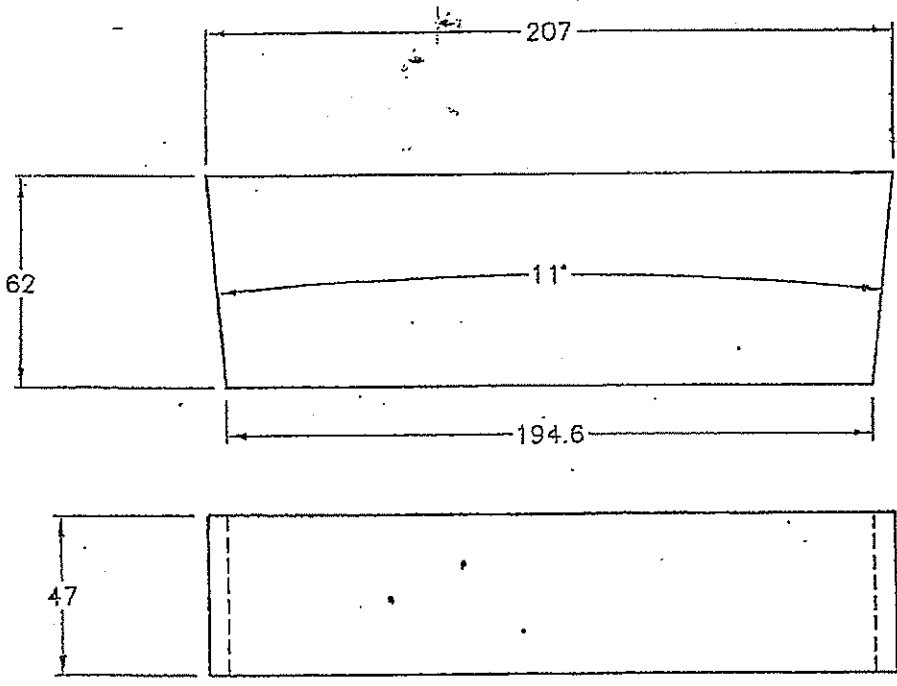

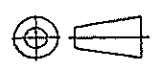
Sl.No.	DRG. No.	DESCRIPTION	MATERIAL	No. OFF	PER PCE	TOTAL	REMARKS									
EQPT.	600KG VIM				WEIGHT kg											
DEPT.	MELT SHOP - 2					TOTAL Wt. kg										
W.D.No.	06/5/118															
DESIGNED	NAME	DATE	 <b>Mishra Dhatu Nigam Ltd</b> <b>SUPER ALLOYS PLANT</b> <b>HYDERABAD</b>													
SCAND.	KBR	21/06														
CHKD/COMP	AKM	22/06	▽▽▽	▽▽	▽	▽	SUPERSEDES									
APPROVED	L.A.C.	25/06	N1	N2	N3	N4	N5	N6	N7	N8	N9	N10	N11	N12	SUPERSEDED BY	
			0.025	0.05	0.1	0.2	0.4	0.8	1.6	3.2	6.3	12.5	25	50		
FINISH	IF NOT SHOWN	SURFACE FINISH IN $\mu$ m AS PER IS:696 - 1972														
SCALE	1:2	TITLE	<b>HOLD DOWN BLOCK</b>										DRG. No.	<b>M04P530-06-03-A4</b>		
			<b>600 kg VIM FURNACE</b>										SHEET	7	OF	7

**SPECIAL TERMS AND CONDITIONS**

1. Techno Commercial bids are invited from interested Bidders against this open tender notice.
2. The list of stores with detailed specifications and approximate annual demand is given in this tender notice. Quantities indicated are indicative and actual quantities to be procured may vary.
3. The detailed techno commercial terms and conditions are mentioned in this tender.
4. **Only Techno commercial bids (No price bids) shall be submitted against this tender.** As a token of confirmation, all pages of the tender set duly signed with seal, need to be enclosed along with your offer.
5. Offers received on tender opening date shall be opened and processed for techno commercial evaluation. Wherever required, MIDHANI may seek clarifications from participating bidders.
6. Once the process of techno commercial evaluation is complete, MIDHANI shall issue letter of acceptance to all bidders whose offers are accepted, authorizing them to be eligible for participating in all the future price discovery cycles of such items, for a period of one year.
7. MIDHANI shall inform unsuccessful bidders also indicating the reasons for rejecting their offers.
8. The techno-commercial bids shall be valid for a period of 15 months from the date of Tender Opening.
9. During the next one year period, as and when and requirement for these items arises, MIDHANI shall issue Tender enquiry to such qualified bidders for price discovery, indicating there in the  
a) Item wise quantity b) Delivery schedule c) EMD amount etc.

This communication shall also indicate if multiple sources are required to execute this requirement. Bidders shall be required to submit offers within 10 days with validity of 30 days.

10. Once the bidder submits EMD and Off-Line Sealed Bid / Online Sealed Bid (OLSB), it shall be construed that quantity tendered and delivery schedule notified, are both acceptable.
11. Participation of price discovery process shall mean that quantity tendered and delivery schedule has been agreed to. Thereafter, Reverse auction process shall be carried out (If Applicable).
12. It shall be obligatory on part of all techno-commercially accepted vendors to participate in all procurement cycles during the one-year period. Non-participation may entail barring in subsequent cycles
13. Thus, same or similar items may have multiple price discovery cycles in a period of one year depending on actual requirement.
14. The techno commercial bids shall be valid for a period of 15 months from the date of this Tender Opening.
15. Pre-Contract Integrity Pact as per enclosed format shall be submitted along with the techno-commercial offer.
16. In case of failure to execute the PO, Risk Purchase action shall be initiated for such un-executed quantities, by resorting to Off-Line Sealed Bid / OLSB with (Reverse auction Process) RAP amongst the balance acceptable bidders. In the absence of sufficient bidders, MIDHANI may resort to other modes of tender. Such a defaulting vendor shall not be allowed to participate in the subsequent procurement cycles. The Security Deposit shall stand forfeited.
17. **Even after the Techno Commercial bids are frozen and one or more procurement cycles completed, there may be some new bidder who may want to participate now, but could not participate at the initial stage due to lack of information. Such bidders shall be afforded an opportunity to submit techno-commercial bids and in case the same are acceptable, they shall be eligible to participate in the price discovery of remaining procurement cycles of the total one year period.**

## GENERAL TERMS AND CONDITIONS FOR INDEGENOUS SOURCES

### 1. DEFINITIONS:

#### PURCHASER:

The term "Purchaser" as used herein shall mean Mishra Dhatu Nigam Limited, incorporated under the Companies Act, 1956, and having its registered office at P.O. Kanchanbagh, Hyderabad - 500 058, India, and shall include its successors and assigns.

#### TENDERER:

The term "Tenderer" shall mean the person, firm or corporation submitting a tender against the Invitation to tender and shall include his/its heirs, executors, administrators, legal representatives, successors and assigns.

2. Any Order resulting from this invitation to tender shall be governed by our General Terms and Conditions of Contract and the supplier quoting against this enquiry Shall be deemed / to have read and understood the same.
3. Where counter terms and conditions have been offered by the Tenderer, the purchaser shall not be governed by these unless specific acceptances have been given in writing in the order by the Purchaser
4. The offer should be complete in all respects. Full particulars and descriptive literature and drawings should be forwarded along with the quotation. The make of the items offered should be clearly specified. Materials should be offered strictly confirming to our specifications. The deviations if any, should be clearly indicated in the quotation. Test certificates must be produced, wherever required where stipulated samples should be forwarded along with the quotation. Material confirming to IS will be preferred.
5. PRICE (Not to be quoted now): The prices must be in unit shown, inclusive of packing, forwarding, insurance, Octroi duty and delivery charges and should be on FOR destination basis. Offers from local suppliers should be for free delivery at our stores
6. TAXES: The Tenderer shall indicate their GST Registration Number in the quotation with HSN code and applicable rate.
7. DELIVERY: Preference will be given to ex-stock offer. Suppliers submitting offer on forward, delivery basis must indicate the earliest guaranteed delivery date by which the material will be dispatched/ delivered free at our stores from the date of receipt of order. Offers indicating terms such as 'EX-Stock' subject to prior sale, goods remaining unsold as early as possible will not be entertained. The date after the third day of issue or the order will be considered as the date of receipt of the order.
8. **RIGHT OF ACCEPTANCE: The purchaser does not bind himself to accept the lowest or any other tender and reserves the right of accepting the whole or any part of the tender or portion of the quantity offered. Within a period of six months from the date of completion of the order, the**



**Purchaser further reserves the right to place order on the successful tenderer for an additional up to 100% of the original ordered quantity.**

9. **TERMS OF PAYMENT:** Payment of all the bills will be made within a period of 30 days from the date of receipt and acceptance of the material at site.
10. **INSPECTION:** The Purchaser reserves the right to get the Stores inspected before commencement of supplier/ or on arrival at our factory by an inspecting officer authorized by the Purchaser. The Tenderer should be in a position show and/ or send samples of material on demand.
11. **PACKING:** The stores should be securely packed and properly marked to avoid loss or damage in transit by Rail /Road /Air.
12. **TO RECOVER LIQUIDATED DAMAGES:** In the event of unsatisfactory delayed or non supply of materials, the supplier shall be liable to pay by way of liquidated damages at the rate of 1% of the total contract price per week or part there of subject to a maximum of 10% of the contract price without prejudice to the right of the purchaser to take any other action. The amount shall also be recoverable from any other contract on account of the supplier.
13. **RISK PURCHASE:** The supply of all items must be completed satisfactory and within the specified period in the order failing which, the Purchaser reserves the right to purchase stores from other sources at the suppliers cost and risk.
14. **GUARANTEE:** The supplier shall guarantee the store supplied in respect of good design, quality and workmanships for a period of 12 months from the commissioning or 18 months from the date of supply whichever is earlier.
15. **Earnest Money Deposit (EMD)- [APPLICABLE AT PRICE DISCOVERY STAGE]:** Tenderer/Bidder are required to furnish EMD of amount specified in tender (NIT) Through Online or in the form Bank Guarantee (BG) is acceptable.  
All Bidders are requested to Submit the "EMD & Security Deposit "online through the below Link: <http://ebs.in/midhani/public/> (or)  
Visit Midhani website <http://www.midhani-india.in> > Purchase > Tenders > TENDER FEE, EMD FEE(EARNEST MONEY DEPOSIT) AND SECURITY DEPOSIT - ONLINE PAYMENT  
In case of EMD/SD in the form of Bank Guarantee(BG), bidder shall submit BG as per format in the tender document,
  - i. In Indian Currency – from a Nationalized Bank or Scheduled Bank encashable in India.
  - ii. In Foreign Currency – from SBI, Frankfurt/ SBI, New York / any Nationalized Bank or Scheduled Bank encashable in India.
  - iii. EMD Bank guarantee shall be valid for a period of 90 days.
  - iv. Security Deposit Bank guarantee shall be valid till material is received and accepted at Midhani.

**EMD Exemption:**

(I) As per Public Procurement Policy (PPP) for Micro & Small Enterprises (MSEs) order, 2012 vide Gazette notification dated 23.03.2012 by Ministry of Micro, Small and Medium Enterprises of Govt of India, the following benefits will be extended to the MSEs.

EMD is exempted for Micro & Small Enterprises (MSEs) registered with DIC/NSIC/KVIC/Udyog Aadhar Memorandum (UAM) issued by MoMSME or any other body specified by Ministry of MSME.

**Purchase Preference:** The following Purchase preference procedure is followed as per Ministry guidelines for award of quantity/order

Type of Tender	Price quoted by MSE	Finalization of tender
(i) If tender can be split	L-1	Full order on MSE
(ii) If tender can be Split	Not L-1 but within L1+15%	20% order on MSE subject to matching with L-1 price
(iii) If tender cannot be split	L-1	Full order on MSE
(iv) If tender cannot be split	Not L-1 but within L-1 +15%	Full order on MSE subject to matching with L-1 Price

**Note:**

(i) In case more than one MSE enterprise quotes same price, the supply/order shall be shared proportionally (to tender quantity) if tender can be split.

(ii) If the MSE who have quoted lowest rate among the MSEs in the price band of L-1 + 15% do not agree to match the rate of L-1 of the tender, then the next ranked MSE bidder who has quoted within the price band of L1+15% in order shall be given chance to match the rate of L-1 for award of the quantity/order.

(ii) All Central PSU's & Government departments / Authorities as well as Original Raw Material Manufacturers may be exempt from submission of EMD in all tenders.

16. **Security Deposit (SD) [APPLICABLE AT PRICE DISCOVERY STAGE]:** The successful tenderer/Bidder shall be required to furnish SD as specified in tender (NIT) within 21 days from the date of Purchase Order. In case SD is not submitted within 21 days from the date of Purchase Order, interest @ 12% p.a. shall be levied for the period of delay beyond 21 days.  
Even in the case of EMD exemption for eligible parties, Security Deposit to be submitted if PO is placed. Security Deposit shall be refundable after material is received and accepted.

**SD Exemption:** All Central PSU and Govt. departments may be exempt from submission of SD in all tenders.

17. **MAKE IN INDIA: [APPLICABLE AT PRICE DISCOVERY STAGE]**  
 Purchase Preference under 'Make in India' Programme as per below mentioned Order and Notifications shall be provided to all Local suppliers:

Public Procurement (Preference to Make in India) Order – 2017 revised dt.29/5/2019.

Local content' means the amount of value added in India which shall, unless otherwise prescribed by the Nodal Ministry, be the total value of the item procured (excluding net domestic indirect taxes) minus the value of imported content in the item (including all customs duties) as a proportion of the total value, in percent.

'Local supplier' means a supplier or service provider whose product or service offered for procurement meets the minimum local content as prescribed under this Order or by the competent Ministries / Departments in pursuance of this order.

1. Requirement of Purchase Preference : Subject to the provisions of this Order and to any specific instructions issued by the Nodal Ministry or in pursuance of this Order, purchase preference shall be given to local suppliers in all procurements undertaken by procuring entities in the manner specified hereunder
  - a. In procurement of all goods, services or works in respect of which the estimated value of procurement is less than INR 50 Lakhs, only local suppliers shall be eligible to bid. However, in procurement of all goods, services or works, in respect of which the Nodal Ministry / Department has communicated that there is sufficient local capacity and local competition, only local suppliers shall be eligible to bid irrespective of purchase value.

Provided that for any particular item, the Nodal Ministry / Department may also prescribe an upper threshold limit, below which procurement shall be made only from local suppliers. Further provided that in any particular case of procurement, if the procuring authority is of the view that the goods, services or works of required quality / specifications etc. may not be available in the country, or sufficient capacity or competition does not exist domestically, and it is necessary to undertake global competitive bidding, the procuring authority may allow the same after recording reasons. In such cases, the provisions of sub-paragraph b or c, as the case may be, shall apply;

- b. In the procurements of goods or works which are not covered by paragraph 1a and which are divisible in nature, the following procedure shall be followed;
  - i. Among all qualified bids, the lowest bid will be termed as L1. If L1 is from a local supplier, the contract for full quantity will be awarded to L1.
  - ii. If L1 bid is not from a local supplier, 50% of the order quantity shall be awarded to L1. Thereafter, the lowest bidder among the local suppliers, will be invited to match the L1 price for the remaining 50% quantity subject to the local supplier's quoted price falling within the margin of purchase preference, and contract for that quantity shall be awarded to such local supplier subject to matching the L1 price. In case such lowest eligible local supplier fails to match the L1 price or accepts less than the offered quantity, the next higher local supplier within the margin of purchase preference shall be invited to match the L1 price for remaining quantity and so on, and contract shall be awarded accordingly. In case some quantity is still left uncovered on local suppliers, then such balance quantity may also be ordered on the L1 bidder.
- c. In procurements of goods or works not covered by sub-paragraph 1a and which are not divisible, and in procurement of services where the bid is evaluated on price alone, the following procedure shall be followed:-
  - i. Among all qualified bids, the lowest bid will be termed as L1. If L1 is from a local supplier, the contract will be awarded to L1.
  - ii. If L1 is not from a local supplier, the lowest bidder among the local suppliers, will be invited to match the L1 price subject to local supplier's quoted price falling within the margin of purchase preference, and the contract shall be awarded to such local supplier subject to matching the L1 price.
  - iii. In case such lowest eligible local supplier fails to match the L1 price, the local supplier with the next higher bid within the margin of purchase preference shall be invited to match the L1 price and so on and contract shall be awarded accordingly. In case none of the local suppliers within the margin of purchase preference matches the L1 price, then the contract may be awarded to the L1 bidder.

2. Minimum local content shall ordinarily be 50%. The nodal ministry may prescribe a higher or lower percentage in respect of any particular item and may prescribe the manner of calculation of local content.

Nodal Ministry has prescribed the following local content for Midhani items as given below.

S. No.	Items Notified under PPP (MII) order	% of Local content to qualify as domestically manufactured
1	Design Manufacturing, supply, Erection and commissioning of Furnaces	25%
2	Design Manufacturing, supply, erection and Commissioning of capital equipments like rolling Mills, Presses, Hammers etc	10%
3	Design Manufacturing supply, erection and commissioning of capital equipments like Melting furnaces	15%

3. The margin of Purchase Preference shall be 20%
4. The local supplier at the time of tender, bidding or solicitation shall be required to provide self certification that the item offered meets the minimum local content and shall give details of the location(s) at which the local value addition is made.
5. In cases of procurement of value in excess of 10 Crores, the local supplier shall be required to provide a certificate from the statutory auditor or cost auditor of the company (In case of companies) or from a practicing cost accountant or practicing chartered accountant (in respect of suppliers other than companies) giving the percentage of local content.
6. For details please visit the following websitelink.  
[https://dipp.gov.in/sites/default/files/PPP-MII%20Order%20dt%2029th%20May%2019\\_0.pdf](https://dipp.gov.in/sites/default/files/PPP-MII%20Order%20dt%2029th%20May%2019_0.pdf)
7. Also please see DDP Notification No. 59011/8/2015-D(HAL-II) issued on different dates which mentions the minimum specific local content etc for consideration as local supplier.

**18. ADDENDA TO TENDER DOCUMENTS:**

The Purchaser reserves the rights to issue addenda to the tender documents to clarify, modify, supplement or delete any of the condition, clauses or items stated in the tender documents issued with this Invitation to Tender. Each addendum issued will be uploaded on MIDHANI website.

**19. NO CLAIM OR COMPENSATION FOR SUBMISSION OF TENDER:**

The tenderers whose tenders are not accepted shall not be entitled to claim any costs, charges and expenses of the tender, incidental to or incurred by them, through or in connection with their submission of tenders even though the Purchaser may elect to withdraw the invitation to tender.

**20. LOWEST TENDER NOT NECESSARY TO BE ACCEPTED:**

The Purchaser is not bound to accept the lowest or any tender or to assign reasons for its non-acceptance. The Purchaser also reserves the right to accept the tender either in whole or in part.

**21. PRICE NEGOTIATIONS:**

Price negotiations as such shall not be held, except in the case of negotiations with the lowest tenderer and accordingly, the tenderers shall have to submit their best commercial bids.

**22. ARBITRATION:**

Any dispute(s) or difference(s) whatsoever arises under or out of or in connection with this contract, or in respect of any defined legal relationship associated therewith or derived there from, shall be resolved/settled by arbitration in accordance with the International Centre for Alternative Dispute Resolution (ICADR) Arbitration Rules 1996. The authority to appoint the arbitrator(s) shall be the International Centre for Alternative Dispute Resolution (ICADR). And will provide administrative services in accordance with ICAR Arbitration Rules 1996. The seat of arbitration shall be India. The language of the arbitration proceeding shall be English. The place of arbitration proceedings shall be Hyderabad, Indian.

For Government Organisation/ PSU Organisation

“Arbitration Clause: In the event of any dispute or difference relating to the interpretation and application of the provisions of commercial contract(s) between Central Public Sector Enterprise (CPSEs)/ Port Trusts inter se and also between CPSEs and Govt. Dept. /Organisation (excluding disputes concerning Railways, Income Tax, Customs & Excise Dept.), such disputes or differences shall be taken up by either party for resolution through AMRCD as mentioned in DPE OM No.4(1)/2013-DPE(GM)/FTS-1835 dt. 22.05.2018”

**23. Jurisdiction:** The contract shall be subject to the exclusive jurisdiction of the courts within the local limits of Hyderabad, Telangana, India.

**24. BANKRUPTCY ETC.:**

If the Contractor shall become bankrupt or insolvent or cause or suffer any receiver to be appointed of his business or any asset thereof or compound with his creditors, or being a corporation commence to be wound up, or carry on its business under a

Receiver for the benefits of its creditors or any of them, the Purchaser shall be at liberty:

To terminate the contract forthwith upon coming to know the happening of any such event as aforesaid by notice in writing to the Contractor or to the receiver / liquidator

OR

To give such receiver, liquidator or other person the option of carrying out the contract subject to his providing guarantee up to an amount to be agreed for the due and faithful performance of the Contract.

**25. CANCELLATION / SHORT CLOSURE OF PURCHASE ORDER**

The purchaser may, without prejudice to any other remedy for breach of Purchase Order Terms by written notice of default sent to supplier, terminate the purchase order in whole or in part:

- a) If the supplier fails to deliver any or all of the stores within the time period(s) specified in the purchase order, or any extension thereof granted by the Purchaser.
- b) If the supplier fails to perform any other obligation under the purchase order within the period specified in the purchase order or any extension thereof granted by the purchaser.
- c) Purchaser reserves the right to cancel the Purchase Order/ contract on its own under exceptional circumstances

**26. REJECTION :**

The rejected goods at MIDHANI premises will lie at the risk of the Vendor. They should be replaced immediately on receipt of an inspection memo showing the details of goods rejected. In case the rejected goods are not replaced within six weeks from the date of receipt of the inspection memo, MIDHANI is not responsible for any loss, damage and theft, and in addition, MIDHANI reserves the right to recover such amount as may be assessed on account of storage and incidentals or any other charges MIDHANI may have incurred.

The vendor has to lift the rejected material from MIDHANI within 6 months from the date of receipt of the inspection memo. In case of rejected goods are in MIDHANI for more than 6 months, MIDHANI reserves the right to dispose of the same and Vendor shall not have any right for claiming the goods or damages thereof

27. Only one vertical (Company) from a group of companies will be eligible to participate in the tender. MIDHANI reserves the right to reject the bids of all such parties summarily, if it is found that verticals under the same organizations have participated.

**28. SUBMISSION OF TENDER:**

Tenders shall be sent by registered post or put in personally in the sealed Tender Box located at the Corporate Security Gate of Midhani. The Tender cover shall superscribe our Tender Number and due date.

The tenders received after the stipulated time (10:30 hrs IST) and due date, due to any reason whatsoever will not be considered.

29. COO (Country Of Origin) certificate to be issued by chambers of commerce to avail discount in preferential custom duty amount in Indian customs.

**30. COUNTERFEIT PARTS:**

MIDHANI requires its supplier to take steps to eliminate the counterfeit (or) suspect counterfeit materials/ parts/ components. We define Counterfeit work as items that are, or contain, unlawful or unauthorized reproductions, substitutions or alterations that have been knowingly mismarked, misidentified or otherwise misrepresented to be an authentic, unmodified material/ parts/ component from the original manufacturer. Unlawful or unauthorized substitution includes used items represented as new or the false identification of Grade, Serial number / Heat number, Lot number and date code or performance characteristics/Test certificate/Coc / CoA. Suppliers of raw materials/ parts/ components are used fulfilling Purchase orders of MIDHANI LTD. Distributors shall only purchase materials/ components directly from original manufacturers.

### 31. TRADE PRACTICES:

Supplier will, at all times, refrain from engaging in any illegal, unfair or deceptive trade practices or unethical business practices. Supplier shall at its expense obtain any and all permits, licences, authorizations, and/or certificates that may be required in any jurisdiction or by any regulatory or administrative agency in connection with its activities hereunder. Supplier shall ensure that its employees are aware of:

- Their contribution to product or service conformity
- Their contribution to product safety, and
- Their contribution to the importance of ethical behaviour.

**INTEGRITY PACT**

Between

**Mishra Dhatu Nigam Limited (MIDHANI)** hereinafter referred to as **“The Principal”**,  
and

..... hereinafter referred to as **“The Bidder/ Contractor”**

**Preamble**

The Principal intends to award, under laid down organizational procedures, contract/s for.....The Principal values full compliance with all relevant laws of the land, rules, regulations, economic use of resources and of fairness / transparency in its relations with its Bidder(s) and / or Contractor(s).

In order to achieve these goals, the Principal will appoint Independent External Monitors (IEMs) who will monitor the tender process and the execution of the contract for compliance with the principles mentioned above.

**Section 1 – Commitments of the Principal**

- (1) The Principal commits itself to take all measures necessary to prevent corruption and to observe the following principles:-
  - a. No employee of the Principal, personally or through family members, will in connection with the tender for , or the execution of a contract, demand, take a promise for or accept, for self or third person, any material or immaterial benefit which the person is not legally entitled to.
  - b. The Principal will, during the tender process treat all Bidder(s) with equity and reason. The Principal will in particular, before and during the tender process, provide to all Bidder(s) the same information and will not provide to any Bidder(s) confidential / additional information through which the Bidder(s) could obtain an advantage in relation to the tender process or the contract execution.
  - c. The Principal will exclude from the process all known prejudiced persons.
- (2) If the Principal obtains information on the conduct of any of its employees which is a criminal offence under the IPC/PC Act, or if there be a substantive suspicion in this regard, the Principal will inform the Chief Vigilance Officer and in addition can initiate disciplinary actions.

**Section 2 – Commitments of the Bidder(s)/ Contractor(s)**

- (1) The Bidder(s)/ Contractor(s) commit themselves to take all measures necessary to prevent corruption. The Bidder(s)/ Contractor(s) commit themselves to observe the following principles during participation in the tender process and during the contract execution.
  - a. The Bidder(s)/ Contractor(s) will not, directly or through any other person or firm, offer, promise or give to any of the Principal’s employees involved in the tender process or the execution of the contract or to any third person any material or other benefit which he/she is not legally entitled to, in order to obtain in exchange any advantage of any kind whatsoever during the tender process or during the execution of the contract.



- b. The Bidder(s)/ Contractor(s) will not enter with other Bidders into any undisclosed agreement or understanding, whether formal or informal. This applies in particular to prices, specifications, certifications, subsidiary contracts, submission or non-submission of bids or any other actions to restrict competitiveness or to introduce cartelization in the bidding process.
  - c. The Bidder(s)/ Contractor(s) will not commit any offence under the relevant IPC/PC Act; further the Bidder(s)/ Contractor(s) will not use improperly, for purposes of competition or personal gain, or pass on to others, any information or document provided by the Principal as part of the business relationship, regarding plans, technical proposals and business details, including information contained or transmitted electronically.
  - d. The Bidder(s)/Contractors(s) of foreign origin shall disclose the name and address of the Agents/representatives in India, if any. Similarly the Bidder(s)/Contractors(s) of Indian Nationality shall furnish the name and address of the foreign principals, if any. Further details as mentioned in the “Guidelines on Indian Agents of Foreign Suppliers” shall be disclosed by the Bidder(s)/Contractor(s). Further, as mentioned in the Guidelines all the payments made to the Indian agent/representative have to be in Indian Rupees only. Copy of the “Guidelines on Indian Agents of Foreign Suppliers” is placed at page No.5.
  - e. The Bidder(s)/ Contractor(s) will, when presenting their bid, disclose any and all payments made, are committed to or intend to make to agents, brokers or any other intermediaries in connection with the award of the contract.
  - f. Bidder(s) /Contractor(s) who have signed the Integrity Pact shall not approach the Courts while representing the matter to IEMs and shall wait for their decision in the matter.
- (2) The Bidder(s)/ Contractor(s) will not instigate third persons to commit offences outlined above or be an accessory to such offences.

**Section 3 - Disqualification from tender process and exclusion from future contracts**

If the Bidder(s)/Contractor(s), before award or during execution has committed a transgression through a violation of Section 2, above or in any other form such as to put their reliability or credibility in question, the Principal is entitled to disqualify the Bidder(s)/Contractor(s) from the tender process or take action as per the procedure mentioned in the “Purchase policy MIDHANI.

**Section 4 – Compensation for Damages**

- (1) If the Principal has disqualified the Bidder(s) from the tender process prior to the award according to Section 3, the Principal is entitled to demand and recover the damages equivalent to Earnest Money Deposit/ Bid Security.
- (2) If the Principal has terminated the contract according to Section 3, or if the Principal is entitled to terminate the contract according to Section 3, the Principal shall be entitled to demand and recover from the Contractor liquidated damages of the Contract value or the amount equivalent to Performance Bank Guarantee.

**Section 5 – Previous transgression**

- (1) The Bidder declares that no previous transgressions occurred in the last three years with any other Company in any country conforming to the anti-corruption approach or with any Public Sector Enterprise in India that could justify his exclusion from the tender process.
- (2) If the Bidder makes incorrect statement on this subject, he can be disqualified from the tender process or action can be taken as per the procedure mentioned in “Purchase policy MIDHANI”.

**Section 6 – Equal treatment of all Bidders / Contractors / Subcontractors**

- (1) In case of Sub-contracting, the Principal Contractor shall take the responsibility of the adoption of Integrity Pact by the Sub-contractor. In case of subcontract (only when the contract provide for sub contracting) the clause is applicable.
- (2) The Principal will enter into agreements with identical conditions as this one with all Bidders and Contractors.
- (3) The Principal will disqualify from the tender process all bidders who do not sign this Pact or violate its provisions.

**Section 7 – Criminal charges against violating Bidder(s) / Contractor(s) / Subcontractor(s)**

If the Principal obtains knowledge of conduct of a Bidder, Contractor or Subcontractor, or of an employee or a representative or an associate of a Bidder, Contractor or Subcontractor which constitutes corruption, or if the Principal has substantive suspicion in this regard, the Principal will inform the same to the Chief Vigilance Officer.

**Section 8 – Independent External Monitor**

- (1) The Principal appoints competent and credible Independent External Monitor for this Pact after approval by Central Vigilance Commission. The task of the Monitor is to review independently and objectively, whether and to what extent the parties comply with the obligations under this agreement.
- (2) The Monitor is not subject to instructions by the representatives of the parties and performs his/her functions neutrally and independently. The Monitor would have access to all Contract documents, whenever required. It will be obligatory for him / her to treat the information and documents of the Bidders/Contractors as confidential. He/ she reports to the C&MD MIDHANI.
- (3) The Bidder(s)/Contractor(s) accepts that the Monitor has the right to access without restriction to all Project documentation of the Principal including that provided by the Contractor. The Contractor will also grant the Monitor, upon his/her request and demonstration of a valid interest, unrestricted and unconditional access to their project documentation. The same is applicable to Sub-contractors.
- (4) The Monitor is under contractual obligation to treat the information and documents of the Bidder(s)/ Contractor(s)/ Sub-contractor(s) with confidentiality. The Monitor has also signed declarations on 'Non-Disclosure of Confidential Information' and of 'Absence of Conflict of Interest'. In case of any conflict of interest arising at a later date, the IEM shall inform C&MD MIDHANI and recuse himself / herself from that case.
- (5) The Principal will provide to the Monitor sufficient information about all meetings among the parties related to the Project provided such meetings could have an impact on the contractual relations between the Principal and the Contractor. The parties offer to the Monitor the option to participate in such meetings.
- (6) As soon as the Monitor notices, or believes to notice, a violation of this agreement, he/she will so inform the Management of the Principal and request the Management to discontinue or take corrective action, or to take other relevant action. The monitor can in this regard submit non-binding recommendations. Beyond this, the Monitor has no right to demand from the parties that they act in a specific manner, refrain from action or tolerate action.

- (7) The Monitor will submit a written report to the C&MD MIDHANI within 8 to 10 weeks from the date of reference or intimation to him by the Principal and, should the occasion arise, submit proposals for correcting problematic situations.
- (8) If the Monitor has reported to the C&MD MIDHANI, a substantiated suspicion of an offence under relevant IPC/ PC Act, and the C&MD MIDHANI has not, within the reasonable time taken visible action to proceed against such offence or reported it to the Chief Vigilance Officer, the Monitor may also transmit this information directly to the Central Vigilance Commissioner.
- (9) The word 'Monitor' would include both singular and plural.

**Section 9 – Pact Duration**

This Pact begins when both parties have legally signed it. It expires for the Contractor 12 months after the last payment under the contract, and for all other Bidders 6 months after the contract has been awarded. Any violation of the same would entail disqualification of the bidders and exclusion from future business dealings.

If any claim is made / lodged during this time, the same shall be binding and continue to be valid despite the lapse of this pact as specified above, unless it is discharged / determined by C&MD MIDHANI.

**Section 10 – Other provisions**

- (1) This agreement is subject to Indian Law. Place of performance and jurisdiction is the Registered Office of the Principal, i.e. Hyderabad.
- (2) Changes and supplements as well as termination notices need to be made in writing. Side agreements have not been made.
- (3) If the Contractor is a partnership or a consortium, this agreement must be signed by all partners or consortium members.
- (4) Should one or several provisions of this agreement turn out to be invalid, the remainder of this agreement remains valid. In this case, the parties will strive to come to an agreement to their original intentions.
- (5) Issues like Warranty / Guarantee etc. shall be outside the purview of IEMs.

\_\_\_\_\_  
(For & On behalf of the Principal)

\_\_\_\_\_  
(For & On behalf of Bidder/ Contractor)

(Office Seal)

(Office Seal)

Place -----

Date -----

Witness 1:

(Name & Address)

\_\_\_\_\_

Witness 2:

(Name & Address)

\_\_\_\_\_

\_\_\_\_\_

\_\_\_\_\_

**GUIDELINES FOR INDIAN AGENTS OF FOREIGN SUPPLIERS**

- 1.0 There shall be compulsory registration of agents for all Global (Open) Tender and Limited Tender. An agent who is not registered with MIDHANI shall apply for registration in the registration form .
- 1.1 Registered agents will file an authenticated Photostat copy duly attested by a Notary Public/Original certificate of the principal confirming the agency agreement and giving the status being enjoyed by the agent and the commission/ remuneration/ salary/ retainer ship being paid by the principal to the agent before the placement of order by MIDHANI.
- 1.2 Wherever the Indian representatives have communicated on behalf of their principals and the foreign parties have stated that they are not paying any commission to the Indian agents, and the Indian representatives working on the basis of salary or as retainer, a written declaration to this effect should be submitted by the party (i.e. Principal) before finalizing the order.
- 2.0 **Disclosure of particulars of agents/ representatives in India, if any.**
- 2.1 Tenderers of Foreign nationality shall furnish the following details in their offers:
- 2.1.1 The Bidder(s)/ Contractor(s) of foreign origin shall disclose the name and address of the agents/ representatives in India if any and the extent of authorization and authority given to commit the Principals. In case the agent/ representative be a foreign Company, it shall be confirmed whether it is existing Company and details of the same shall be furnished.
- 2.1.2 The amount of commission/ remuneration included in the quoted price(s) for such agents/ representatives in India.
- 2.1.3 Confirmation of the Tenderer that the commission/ remuneration, if any, payable to his agents/ representatives in India, may be paid by MIDHANI in Indian Rupees only.
- 2.2 Tenderers of Indian Nationality shall furnish the following details in their offers:
- 2.2.1 The name and address of the foreign principals, if any, indicating their nationality as well as their status, i.e. whether manufacturer or agents of manufacturer holding the Letter of Authority of the Principal specifically authorizing the agent to make an offer in India in response to tender either directly or through the agents/ representatives.
- 2.2.2 The amount of commission/ remuneration included in the price (s) quoted by the Tenderer for himself.
- 2.2.3 Confirmation of the foreign principals of the Tenderer that the commission/ remuneration, if any, reserved for the Tenderer in the quoted price(s), may be paid by MIDHANI in India in equivalent Indian Rupees on satisfactory completion of the Project or supplies of Stores and Spares in case of operation items.
- 2.3 In either case, in the event of contract materializing, the terms of payment will provide for payment of the commission/ remuneration, if any payable to the agents/ representatives in India in Indian Rupees on expiry of 90 days after the discharge of the obligations under the contract.
- 2.4 Failure to furnish correct and detailed information as called for in paragraph 2.0 above will render the concerned tender liable to rejection or in the event of a contract materializing, the same liable to termination by MIDHANI. Besides this there would be a penalty of banning business dealings with MIDHANI or damage or payment of a named sum.

\*\*\*\*\*

